

# Assessment of beamline shielding at the ESRF

P. Berkvens, P. Colomp and R. Kersevan  
European Synchrotron Radiation Facility

# Radiation Protection Policy at the ESRF

## ICRP-60 recommendations



European Union:

Directive 96/29/Euratom of 13/05/1996



France

Decree no. 2002-460 of 4 April 2002, protection of the general public against ionising radiation hazards

Decree no. 2003-296 of 31 March 2003, protection of workers against ionising radiation hazards

Annual dose limit for public = 1 mSv

# Radiation Protection Policy at the ESRF

Modern 3<sup>rd</sup> generation light sources are characterised by the fact that a large number of people come to these facilities to stay for a relatively short period of time:

-  Users
-  Contractors
-  Visitors

Example: duration of experiments at the ESRF

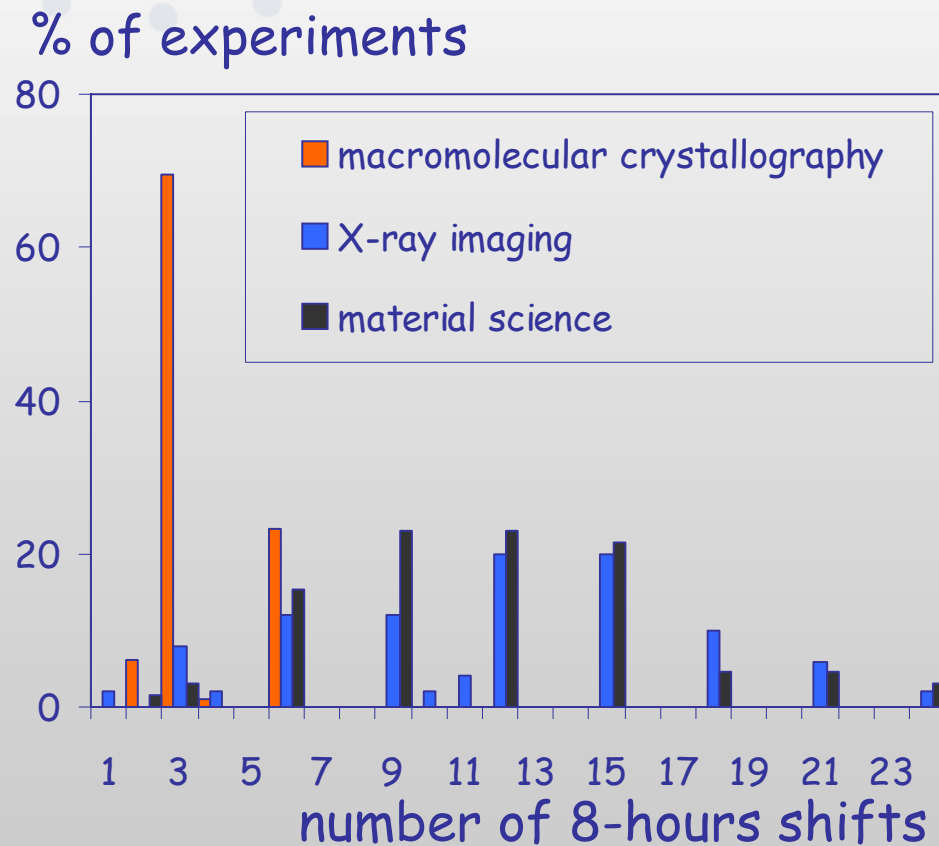

# Radiation Protection Policy at the ESRF

No radiation workers

→  $< 1 \text{ mSv.y}^{-1}$   
 ( $0.5 \text{ } \mu\text{Sv.h}^{-1}$ )

Dose rate varies strongly,  
 e.g. during injection and  
 beam trips

→ limit on dose rate not  
 possible

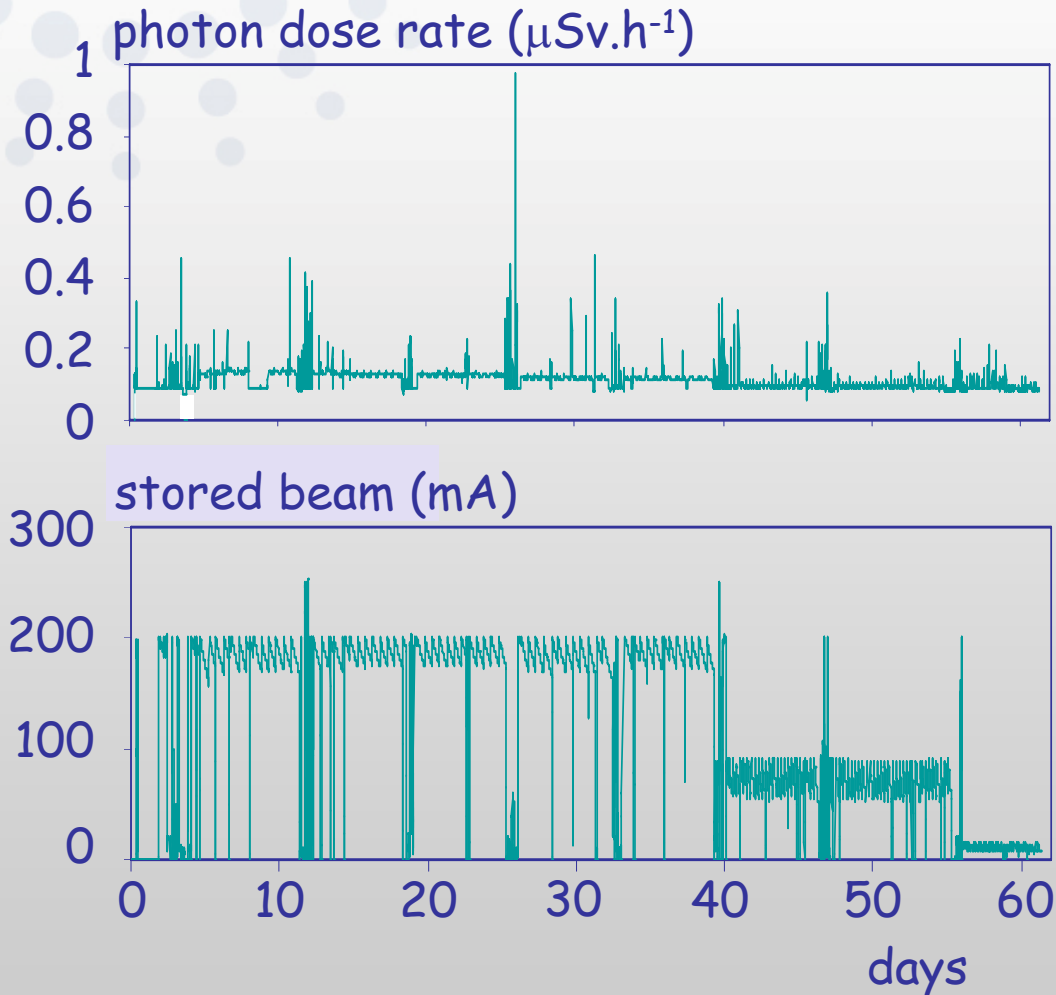

# Radiation Protection Policy at the ESRF

No radiation workers

→  $< 1 \text{ mSv.y}^{-1}$   
 ( $0.5 \text{ } \mu\text{Sv.h}^{-1}$ )

Dose integrated essentially during machine studies and start-up

→ limit on annual dose not sufficient

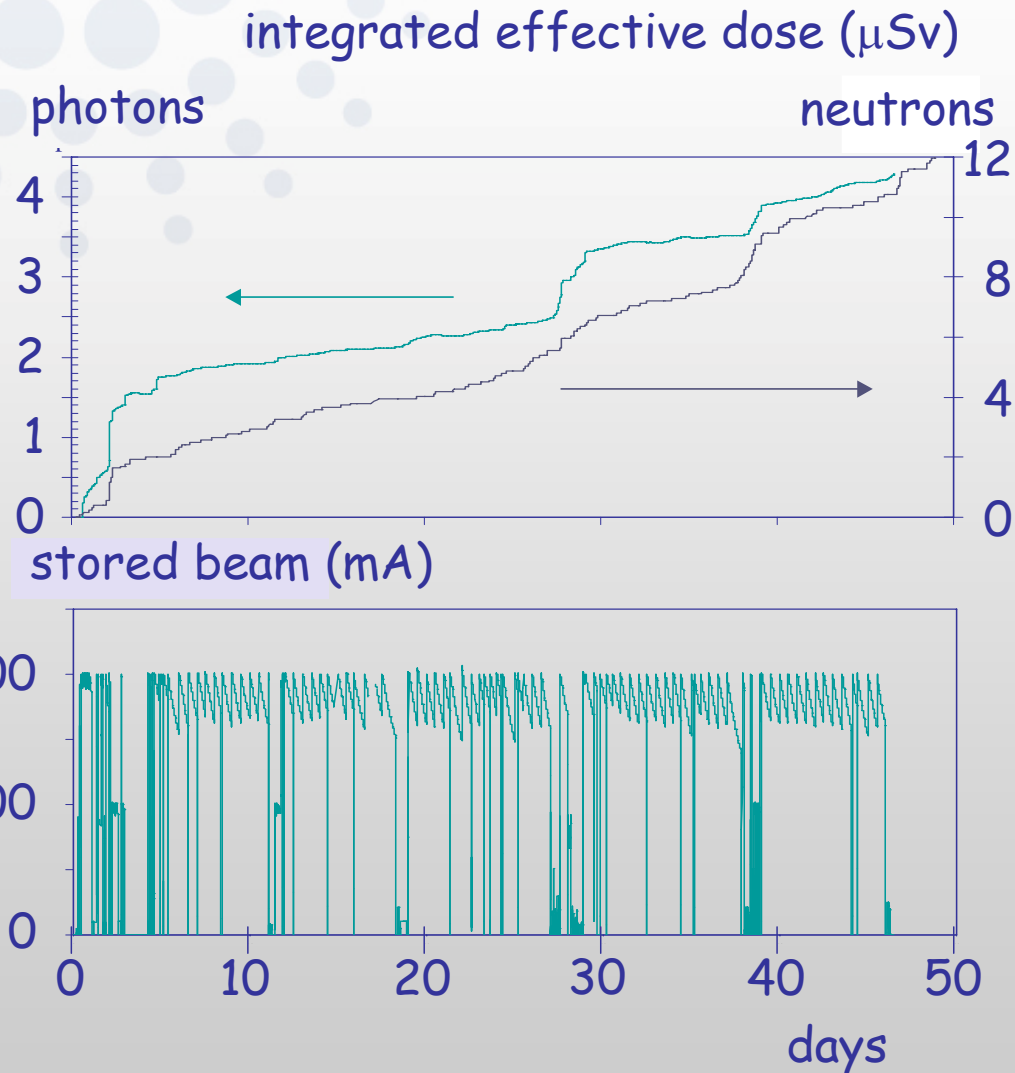

# Radiation Protection Policy at the ESRF

No radiation workers  
 $\rightarrow < 1 \text{ mSv.y}^{-1}$   
 (0.5  $\mu\text{Sv.h}^{-1}$ )

$$\int_{4 \text{ hours}} \dot{H}^*(d) \cdot dt \leq 4 \times 0.5 \mu\text{Sv.h}^{-1} = 2 \mu\text{Sv}$$

## Interlocked radiation monitors:

### Storage ring:

- 64 neutrons monitors
- Interlock on injection

### Beamlines:

- 1 ionisation chamber per beamline
- Interlock on front end



Preconditioning of all new 5 meter long, NEG coated ID vacuum vessels, including upstream and downstream vessels, during one entire run on the dedicated diagnostics/safety straight section, with on-axis bremsstrahlung measurement to validate vessels from a radiation protection point of view.

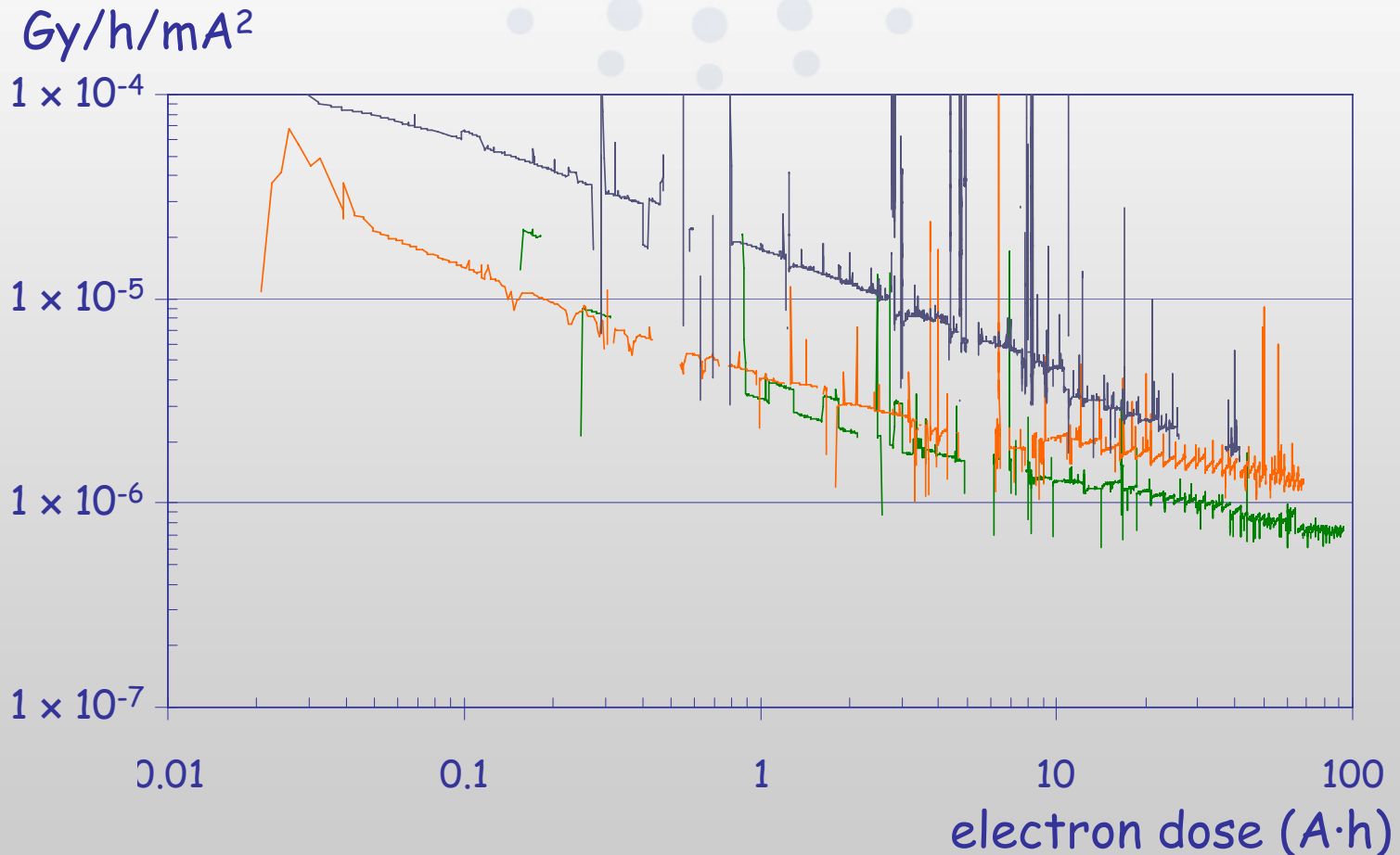



# ESRF

## Storage ring characteristics:

$$E = 6 \text{ GeV}$$

$$I = 200 \text{ mA}$$

$$L = 843 \text{ m}$$

$$\varepsilon_H = 4 \text{ nmrad}$$

$$\varepsilon_V = 0.025 \text{ nmrad}$$

Lifetime:

Multibunch (200 mA): 75 h

16-bunch (90 mA): 9 h

# ESRF

## Storage ring characteristics:

$$E = 6 \text{ GeV}$$

$$I = 200 \text{ mA}$$

$$L = 843 \text{ m}$$

$$\varepsilon_H = 4 \text{ nmrad}$$

$$\varepsilon_V = 0.025 \text{ nmrad}$$

Lifetime:

Multibunch (200 mA): 75 h

16-bunch (90 mA): 9 h

12 December 2006:  
300 mA

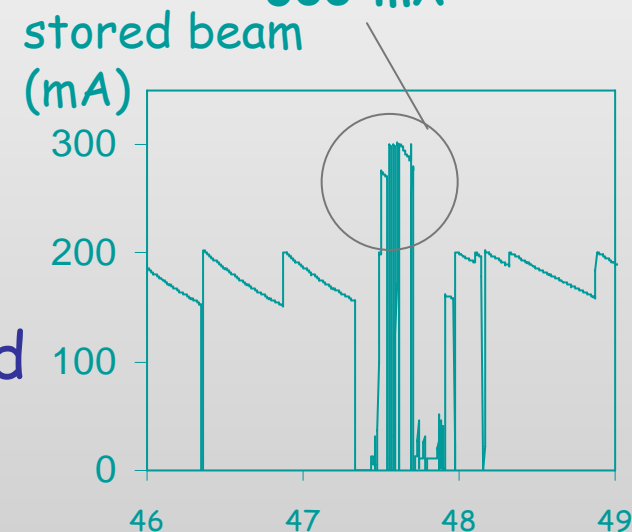

The shielding requirements for the optics hutches of ESRF insertion device beamlines are largely determined by gas-bremsstrahlung (and photo-neutrons), except for 3 wiggler beamlines. The increase of the stored current from 200 mA to 300 mA will more than double the radiation levels outside these optics hutches.

### Gas-bremsstrahlung power:

$$P = C \times \frac{dE}{dx}(E_e) \times p \times I \times L,$$

electron stopping power  
pressure in straight section  
electron beam intensity  
length of straight section

$$\frac{dE}{dx}(E_e) \propto E_e$$

$$p \propto E_e \times I$$

$$P \propto E_e^2 \times I^2 \times L$$



I: 200 mA → 300 mA: P × 2.25

# MOLFLOW: 3D Monte Carlo calculation of pressure distribution in storage ring vacuum chamber (developed by R. Kersevan)

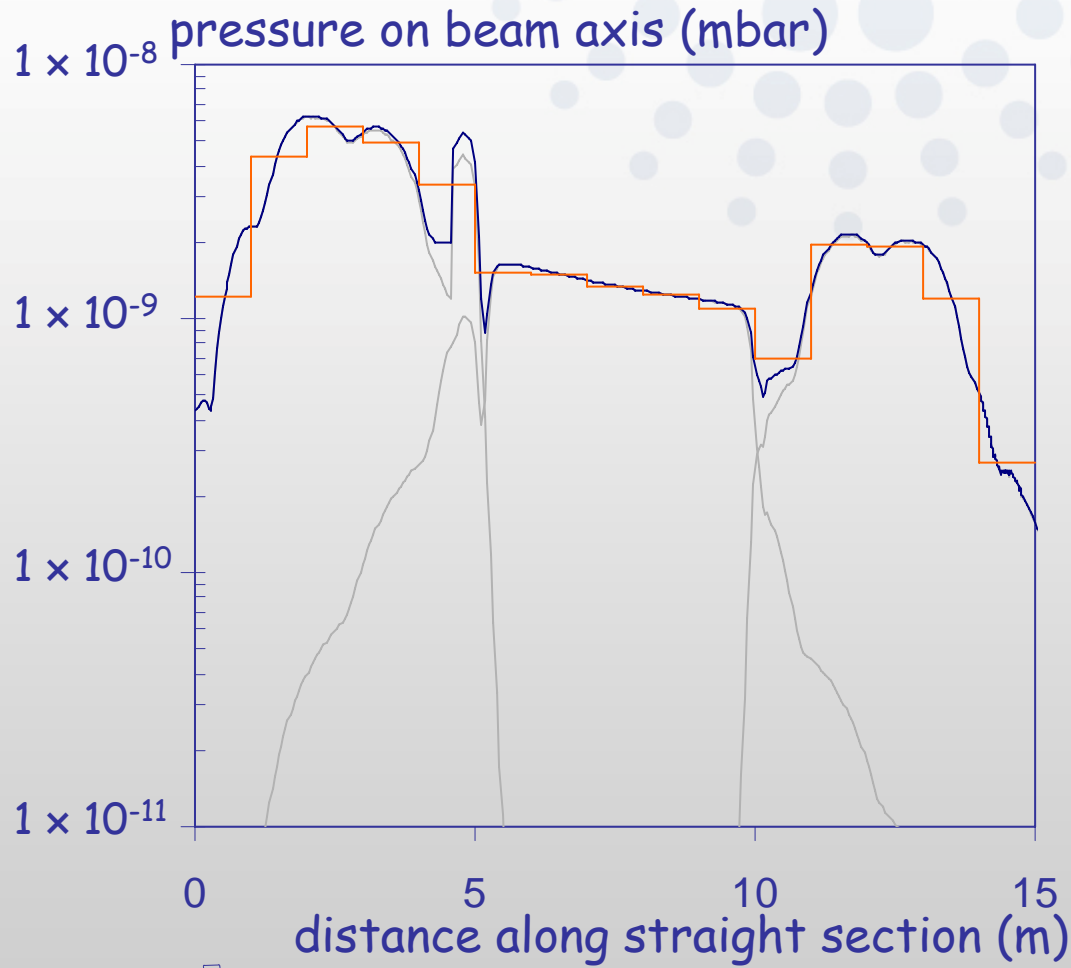

- Pressure distribution from M.C. code *Molflow*
- Pressure distribution for photon sampling in M.C. code *BeamLines*



# MOLFLOW: 3D Monte Carlo calculation of pressure distribution in storage ring vacuum chamber (developed by R. Kersevan)

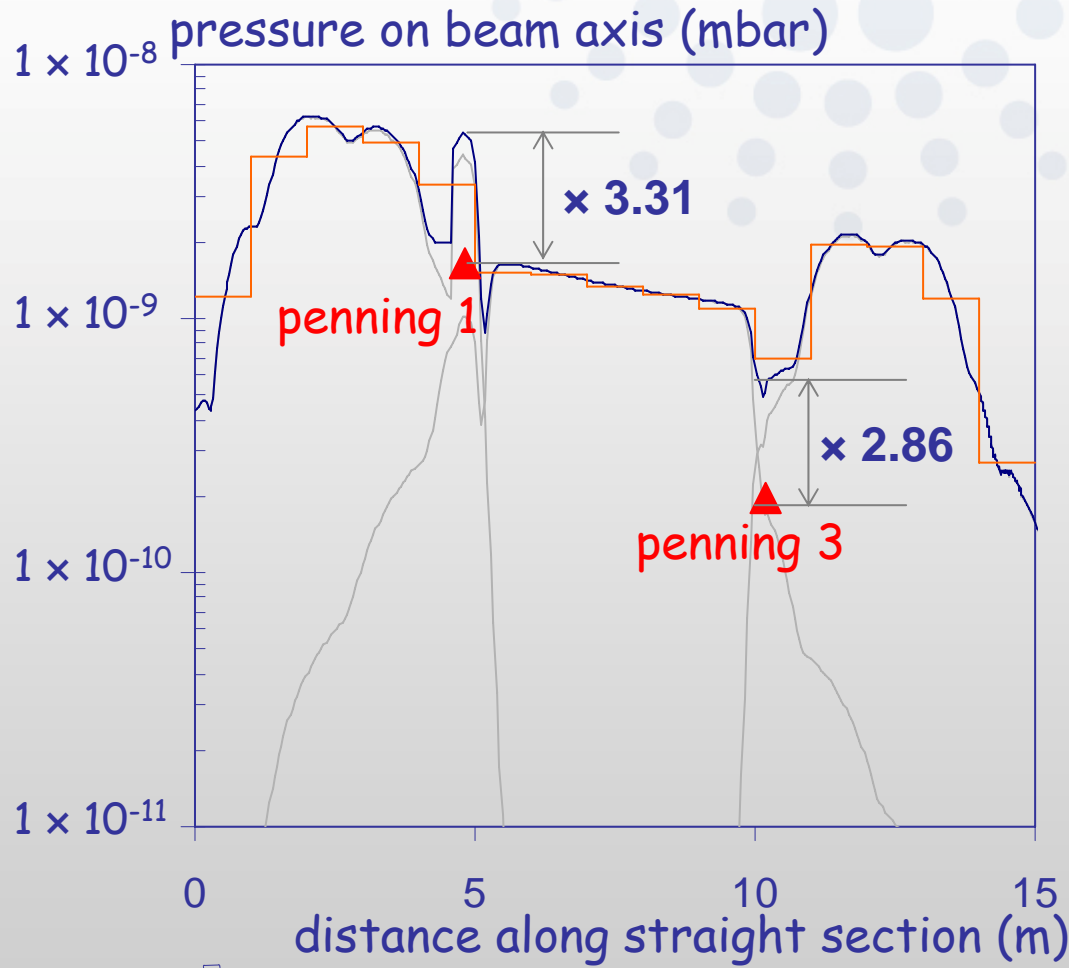

— Pressure distribution from M.C. code *Molflow*

— Pressure distribution for photon sampling in M.C. code *BeamLines*

▲ Pressure at gauge location from M.C. code *Molflow*

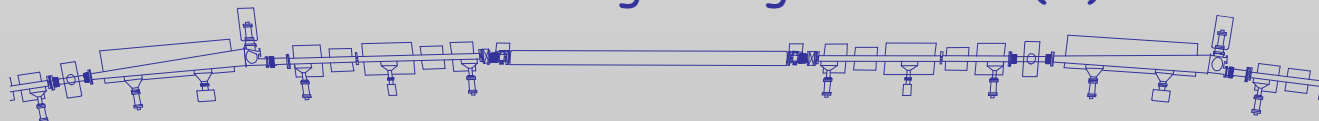

# MOLFLOW: 3D Monte Carlo calculation of pressure distribution in storage ring vacuum chamber (developed by R. Kersevan)

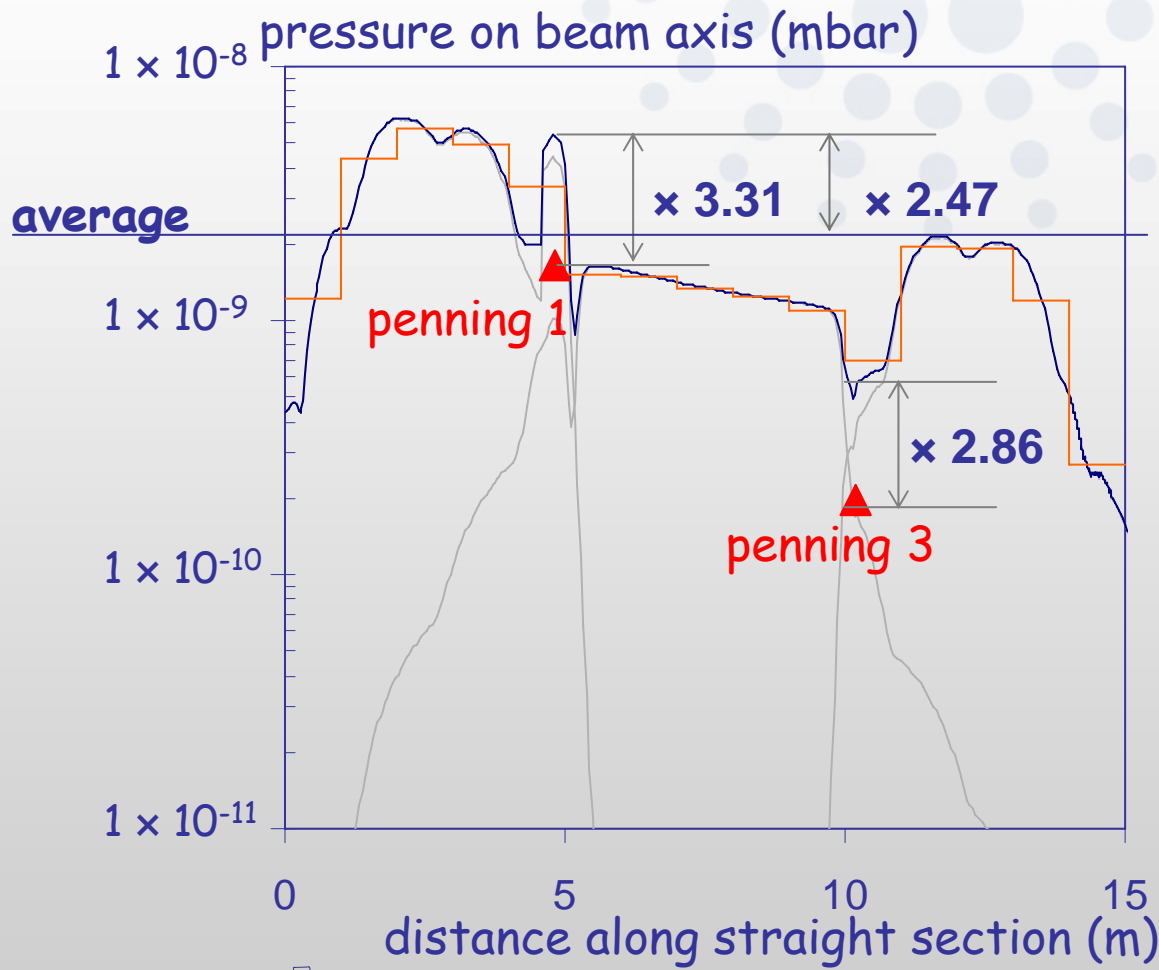

— Pressure distribution from M.C. code *Molflow*

— Pressure distribution for photon sampling in M.C. code *BeamLines*

▲ Pressure at gauge location from M.C. code *Molflow*

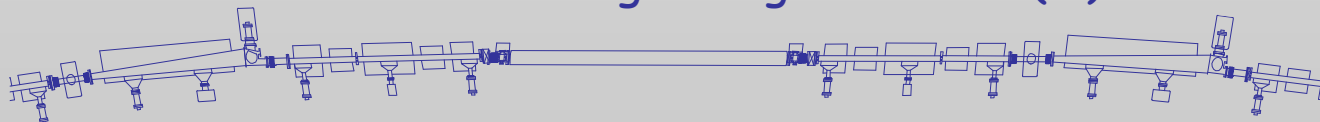

# MOLFLOW: 3D Monte Carlo calculation of pressure distribution in storage ring vacuum chamber (developed by R. Kersevan)

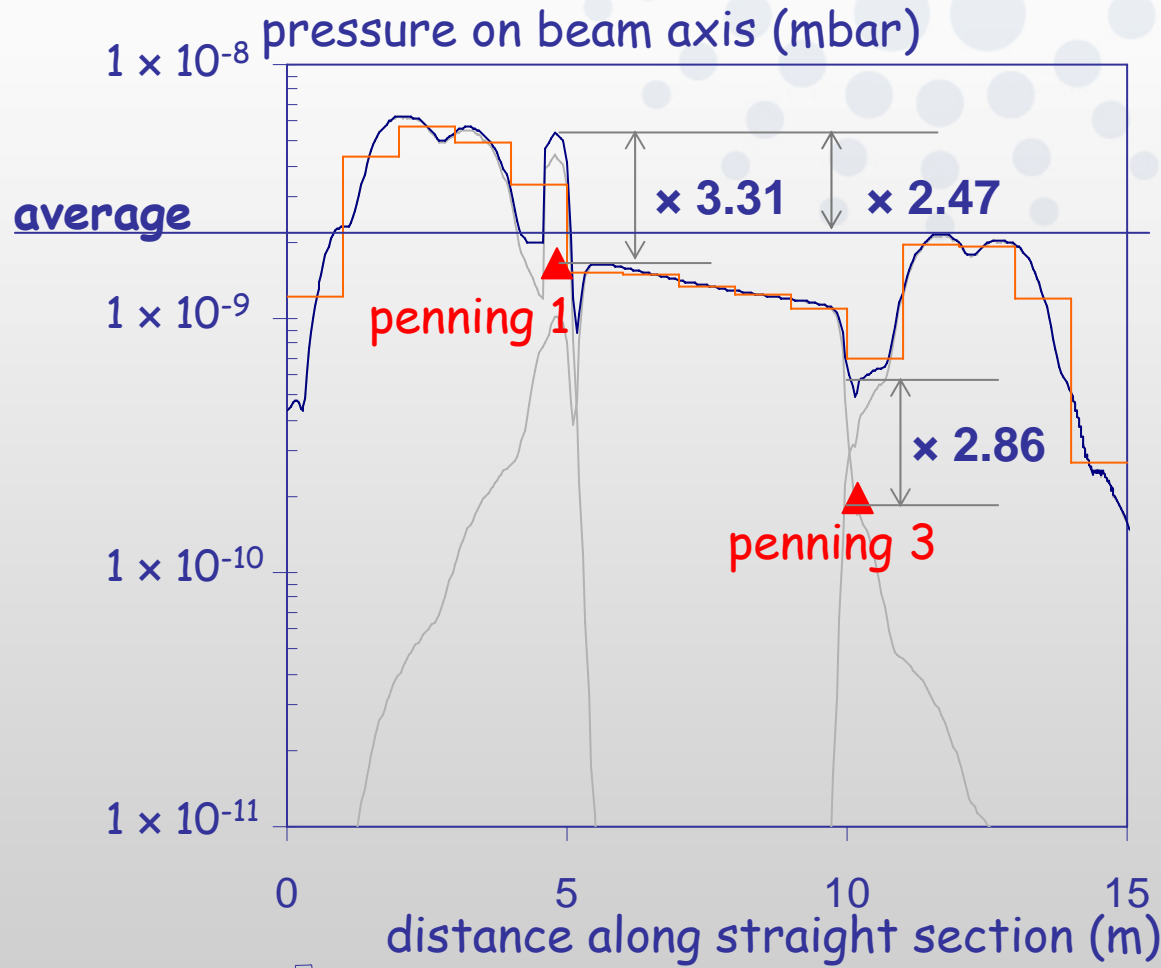

— Pressure distribution from M.C. code *Molflow*

— Pressure distribution for photon sampling in M.C. code *BeamLines*

▲ Pressure at gauge location from M.C. code *Molflow*

*average pressure*<sub>beam axis</sub>

$$\Rightarrow = \frac{3.31}{2.47} = 1.34 \times \text{reading}_{\text{penning 1}}$$

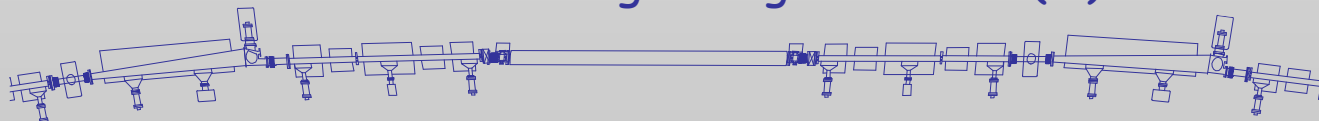

# MOLFLOW: 3D Monte Carlo calculation of pressure distribution in storage ring vacuum chamber (developed by R. Kersevan)

$$\text{average pressure}_{\text{beam axis}} = 1.34 \times \text{reading}_{\text{gauge}}$$

for average pressure of  $1 \times 10^{-9}$  mbar in straight section :

- CV500:  $6.37 \times 10^{-10}$  mbar
- rest:  $1.18 \times 10^{-9}$  mbar

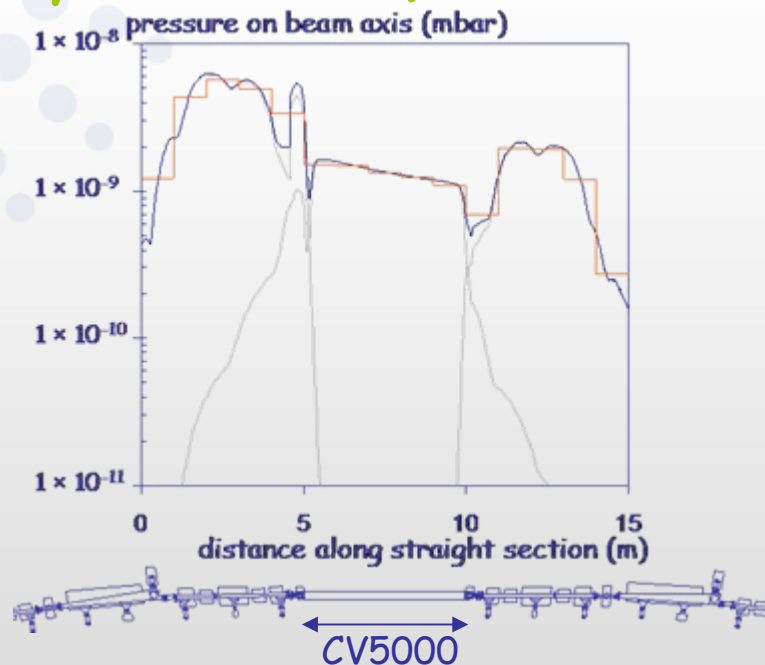

Residual gas composition in straight section (from RGA analysers)

molecule	relative pressure (%) inside CV5000	relative pressure (%) rest of straight section
H <sub>2</sub>	85	80
CO	15	10
CO <sub>2</sub>	-	5
CH <sub>4</sub>	-	3
H <sub>2</sub> O	-	2

Shielding calculations are done with Monte Carlo code *BeamLines* developed by P. Berkvens:

- ✚ Electromagnetic shower description based on EGS4.
- ✚ Bremsstrahlung differential fluence calculated from theoretical cross sections, using realistic pressure distributions and residual gas compositions in the storage ring straight section.
- ✚ Direct sampling of photons (instead of electrons).
- ✚ 3D description of front end and optical components.
- ✚ Photo neutron dose distributions using differential photon track lengths and assuming an isotropic angular distribution.

Examples:

- ✚ ID20 Magnetic scattering beamline;
- ✚ ID12 Circular polarisation beamline.

# Transmission through front end

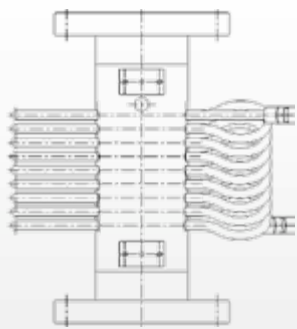

vertical slit  
4 mm  
(± 0.089 mrad)

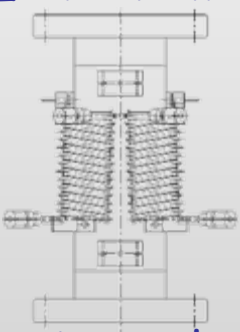

horizontal slit  
2 mm  
(± 0.074 mrad)

22.5 m

13.5 m

distance from middle of  
straight section

6 GeV:  
 $1/\gamma = 0.085 \text{ mrad}$

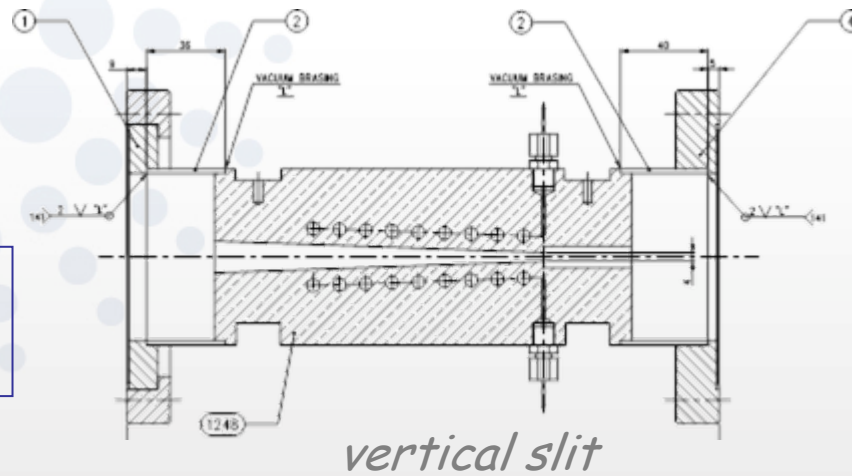

*vertical slit*

photons / MeV

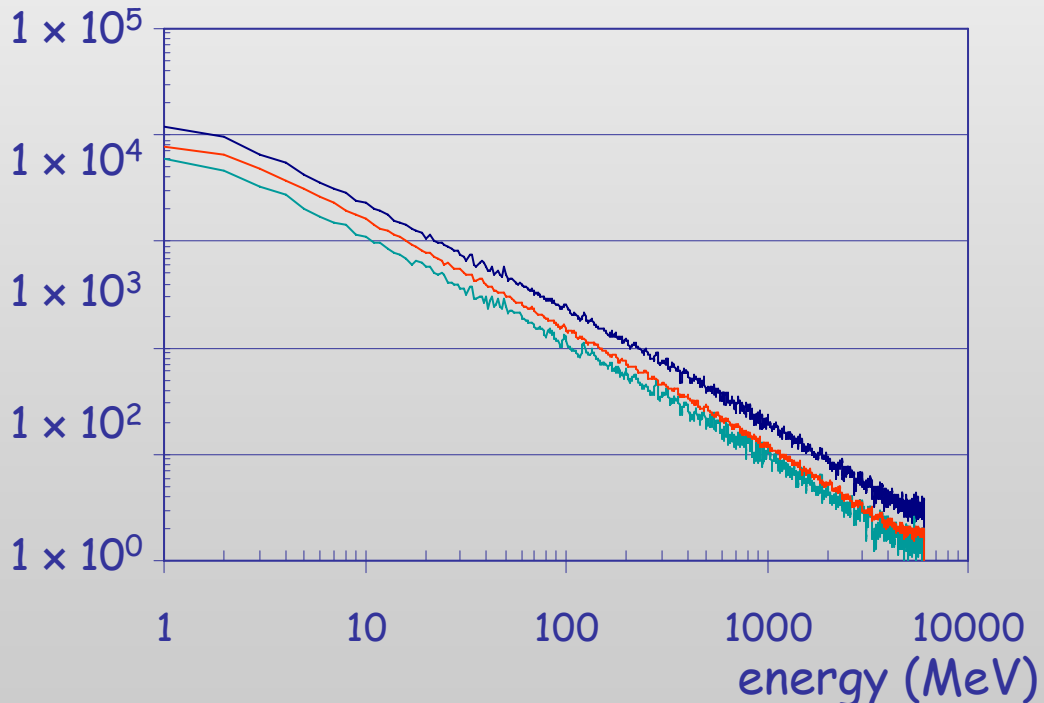

— uncollimated  
— ray-tracing  
— Monte Carlo

# ID20 - Magnetic scattering beamline

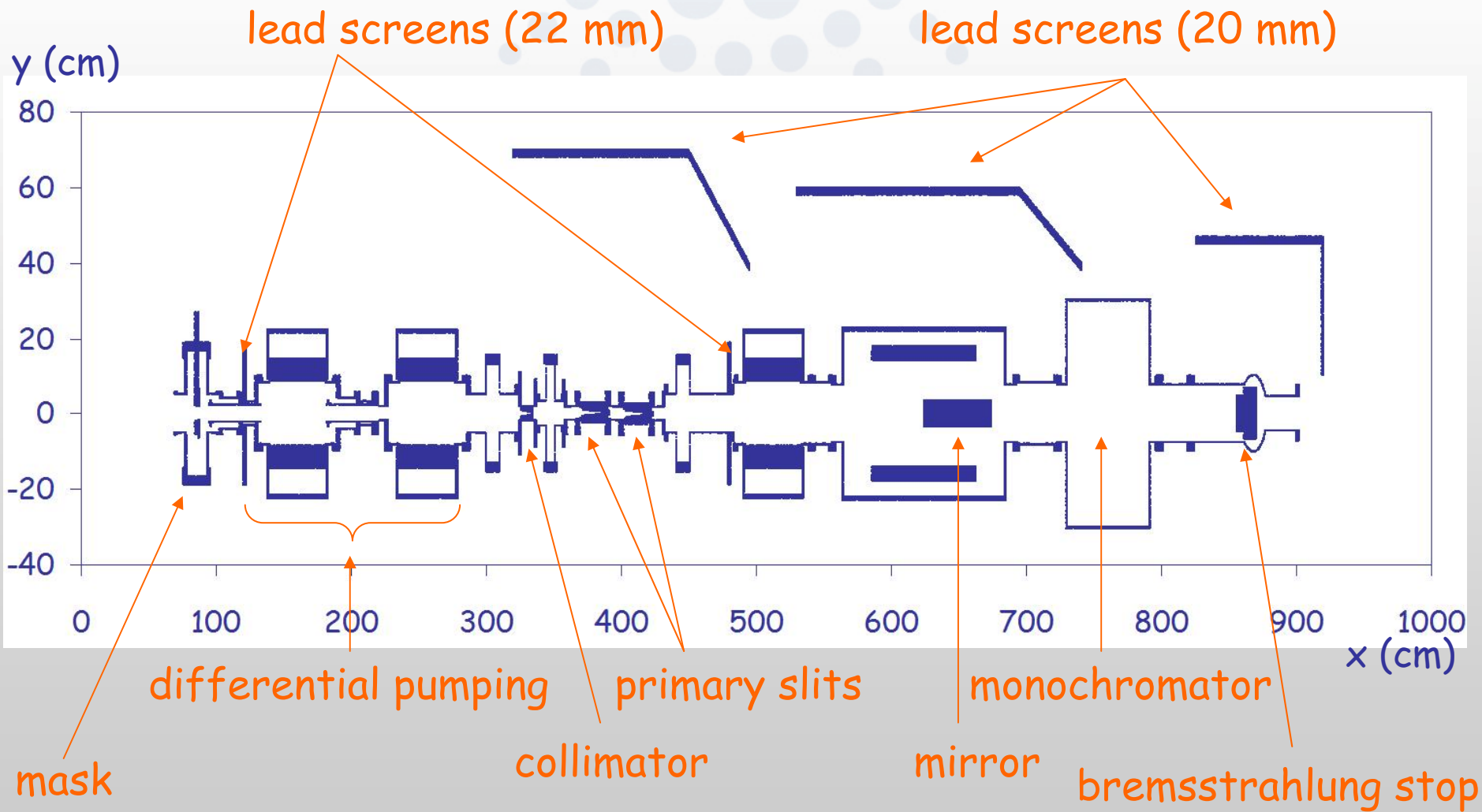

# ID20 - Magnetic scattering beamline

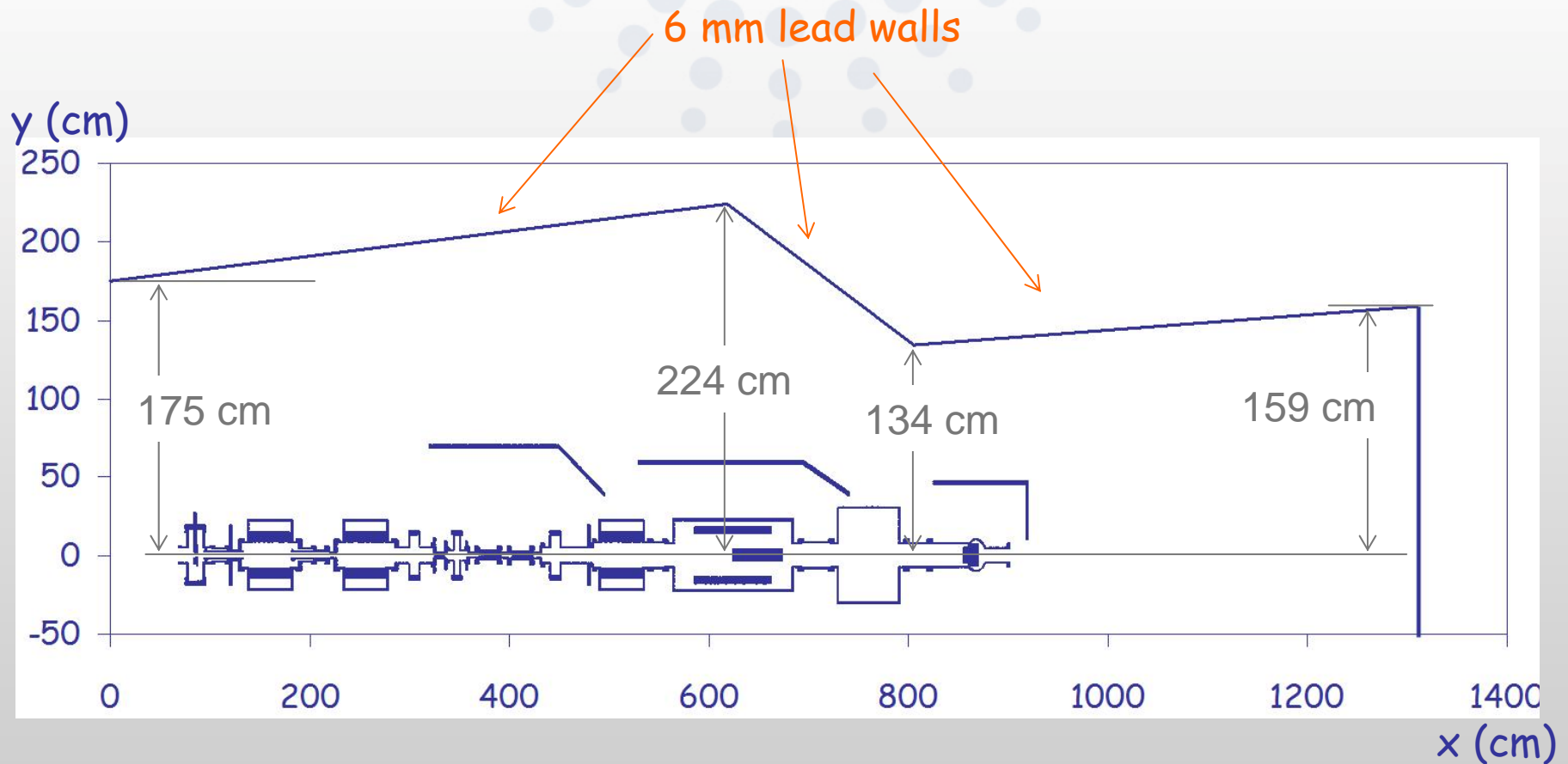

# ID20 - Magnetic scattering beamline

penning gauge no. 1 (mbar)

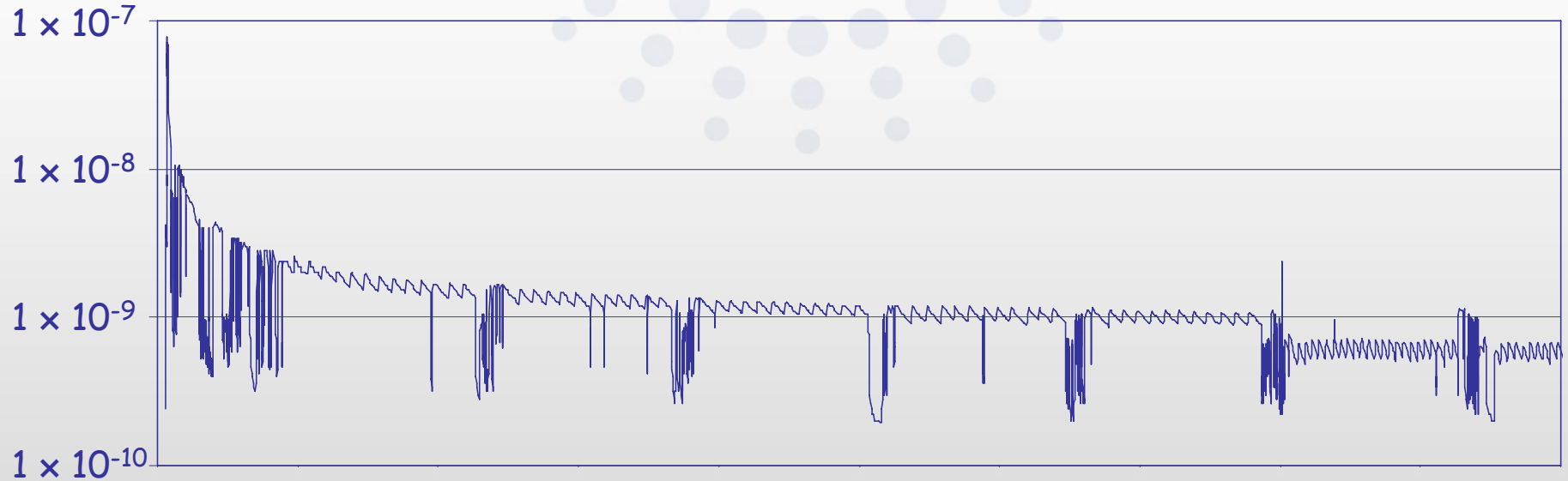

stored beam current (mA)

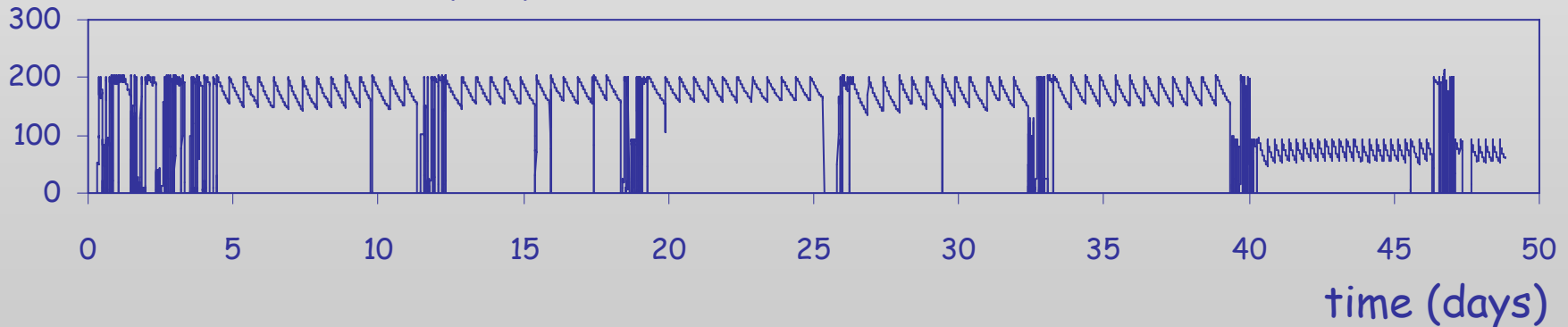

# ID20 - Magnetic scattering beamline

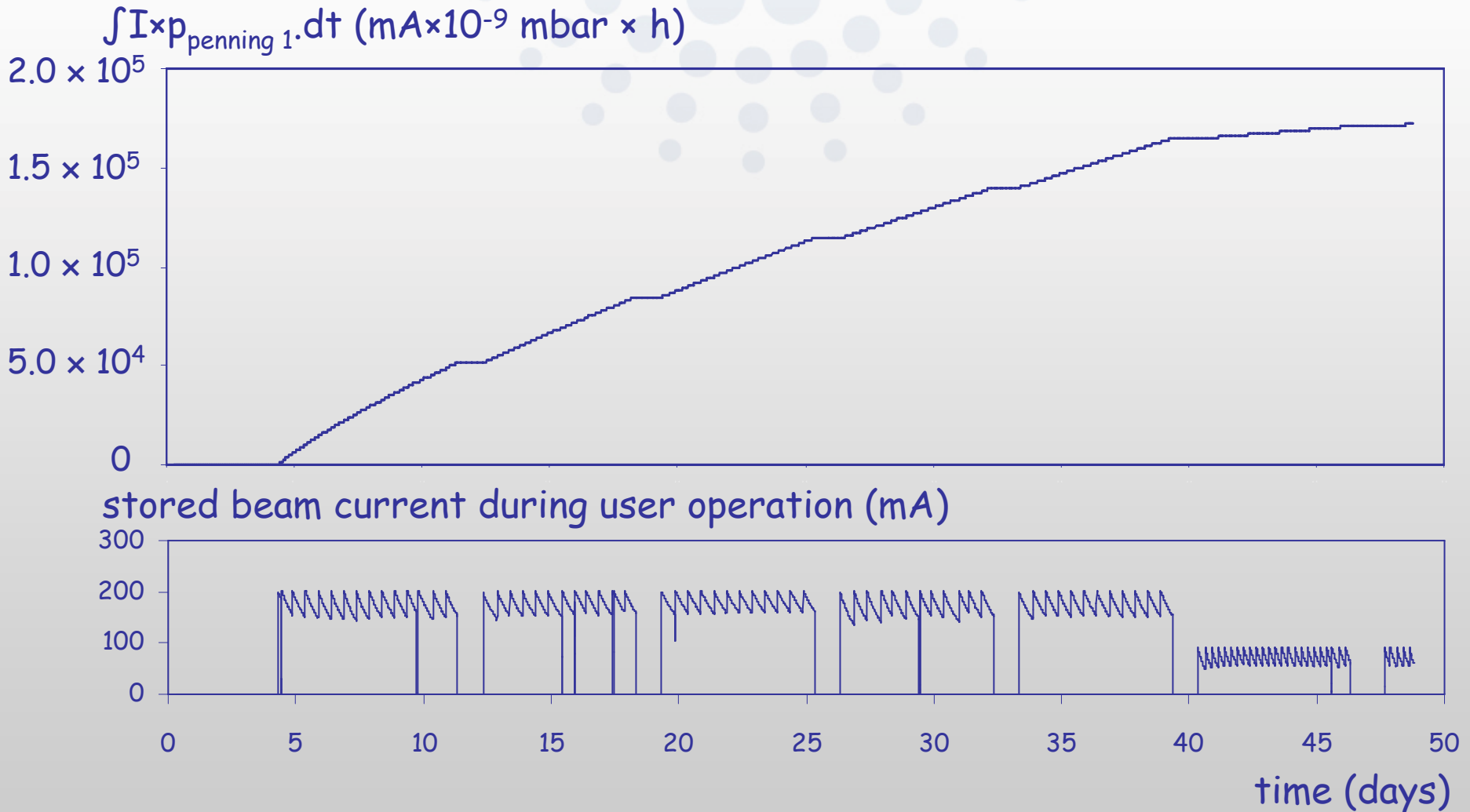

# ID20 - Magnetic scattering beamline

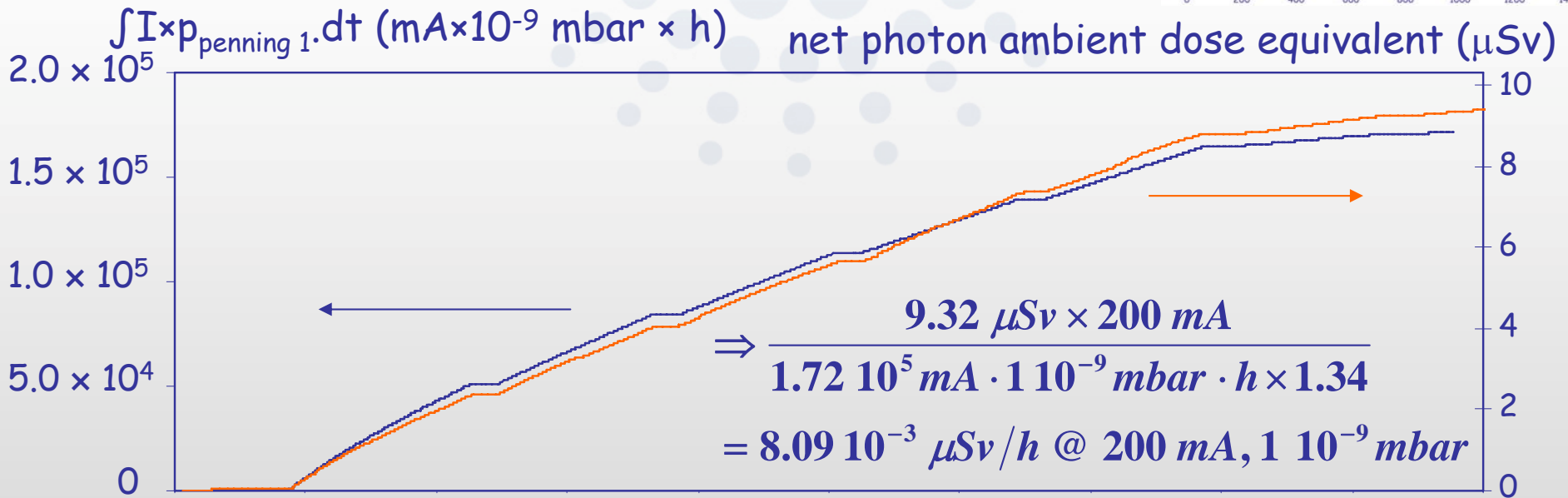
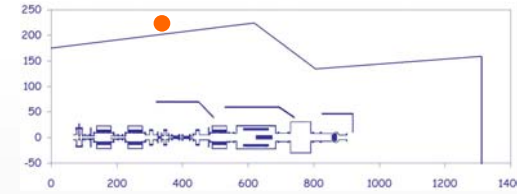

stored beam current during user operation (mA)

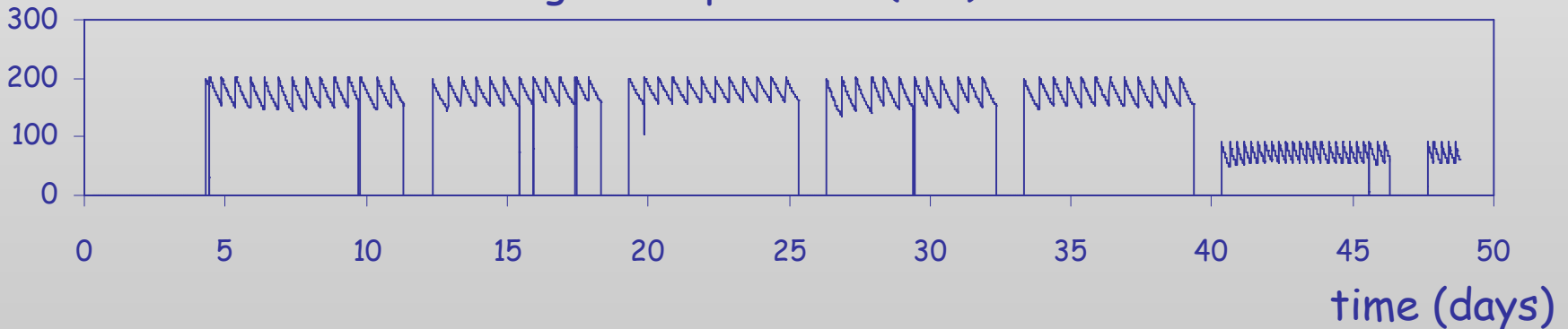

# ID20 - Magnetic scattering beamline

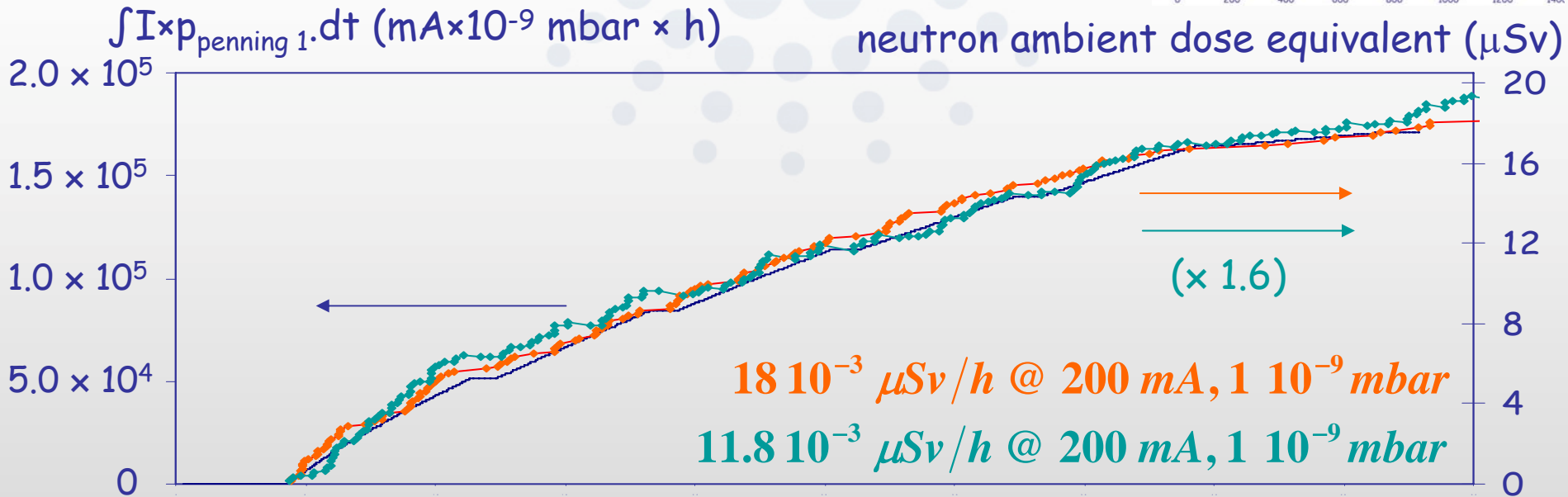
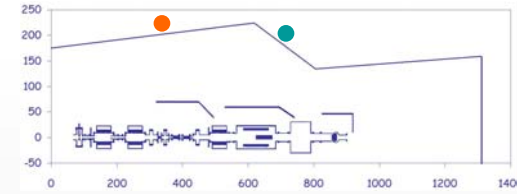

stored beam current during user operation (mA)

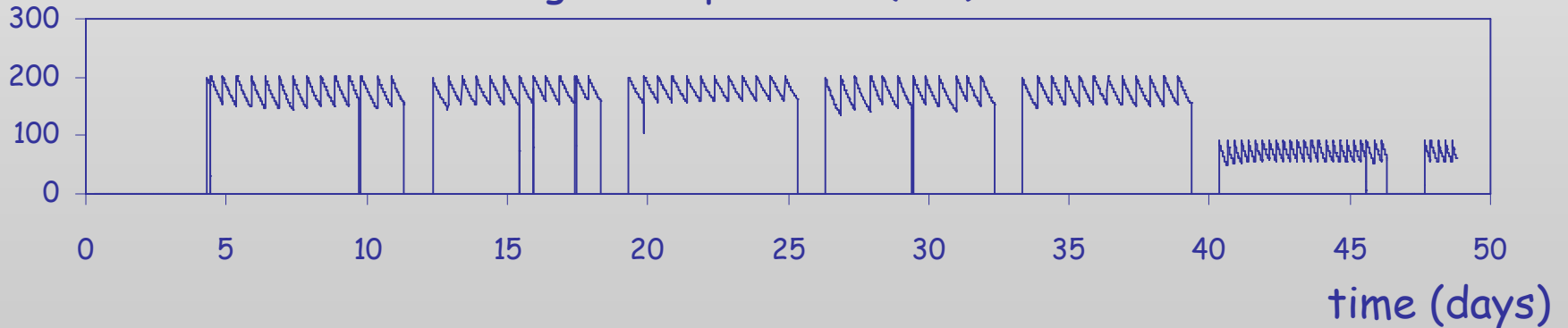

# ID20 - Magnetic scattering beamline

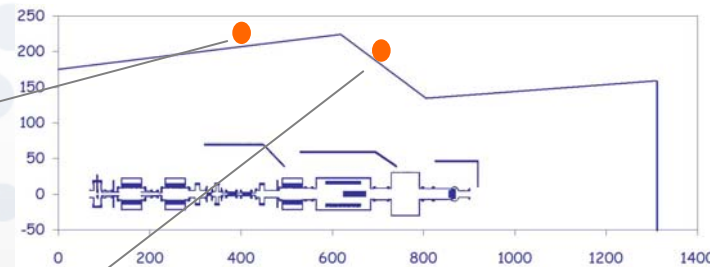

ambient dose equivalent rate ( $\mu\text{Sv/h}$ )

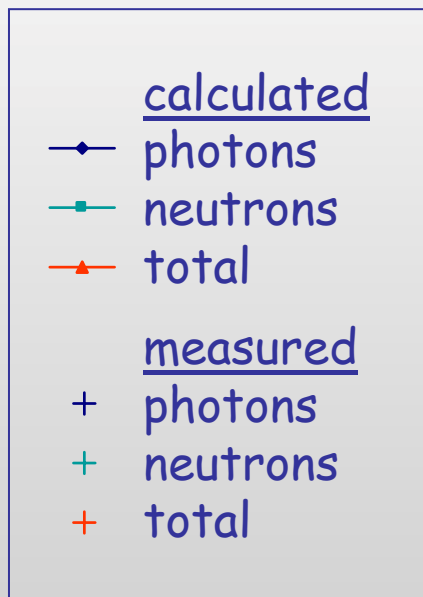
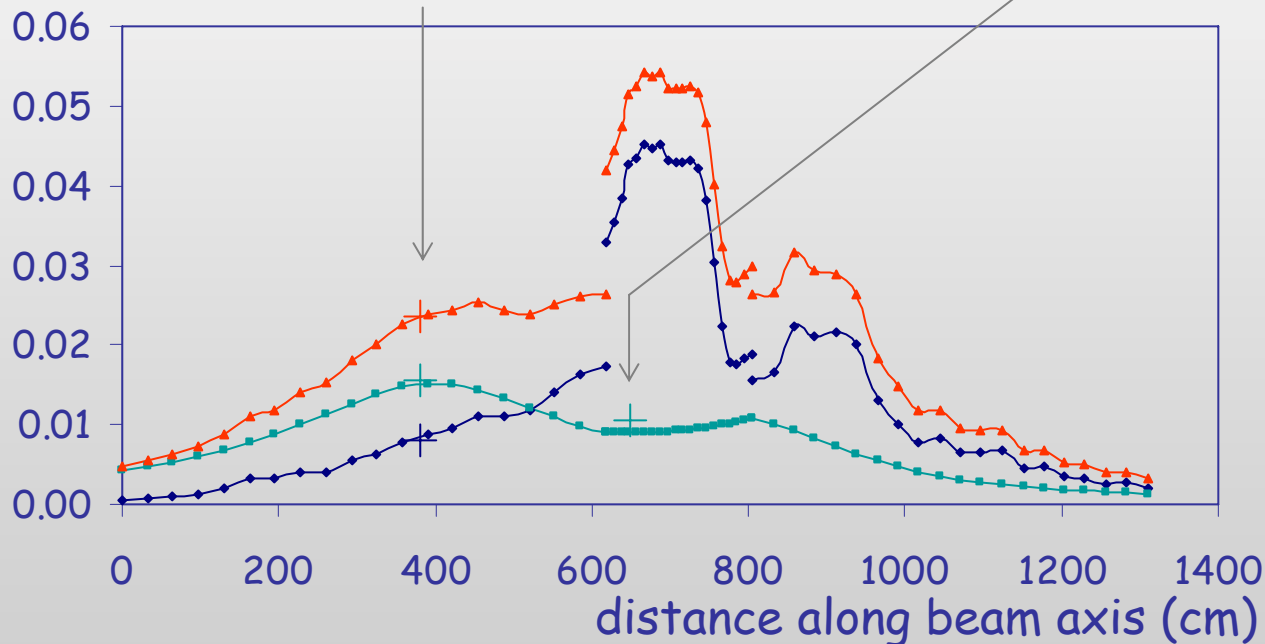

0.5  $\mu\text{Sv/h}$ :  
300 mA,  $6 \times 10^{-9}$  mbar

average pressure in straight section:  $1 \times 10^{-9}$  mbar  
stored beam current: 200 mA

# ID12 - Circular polarisation beamline

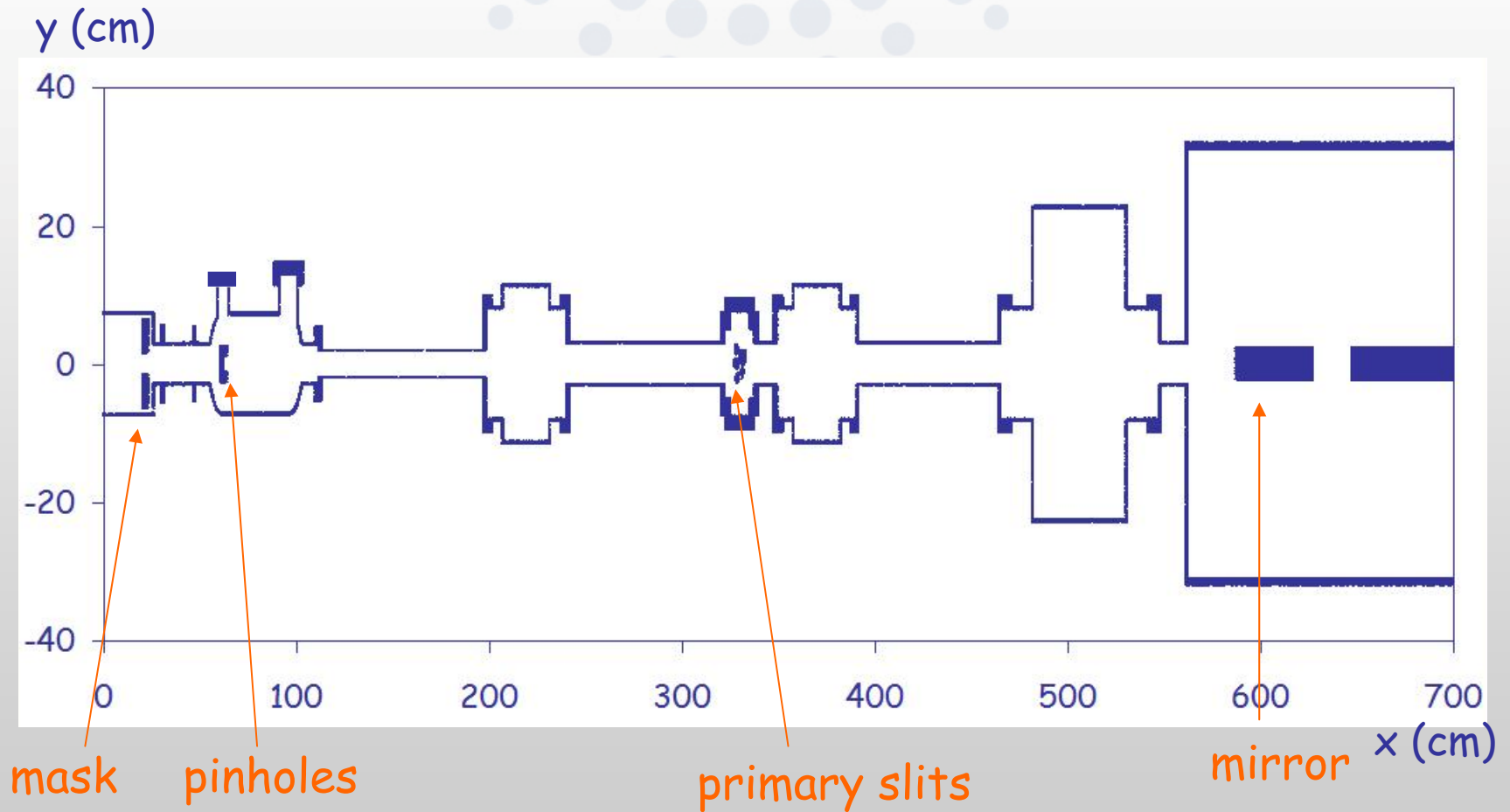

# ID12 - Circular polarisation beamline

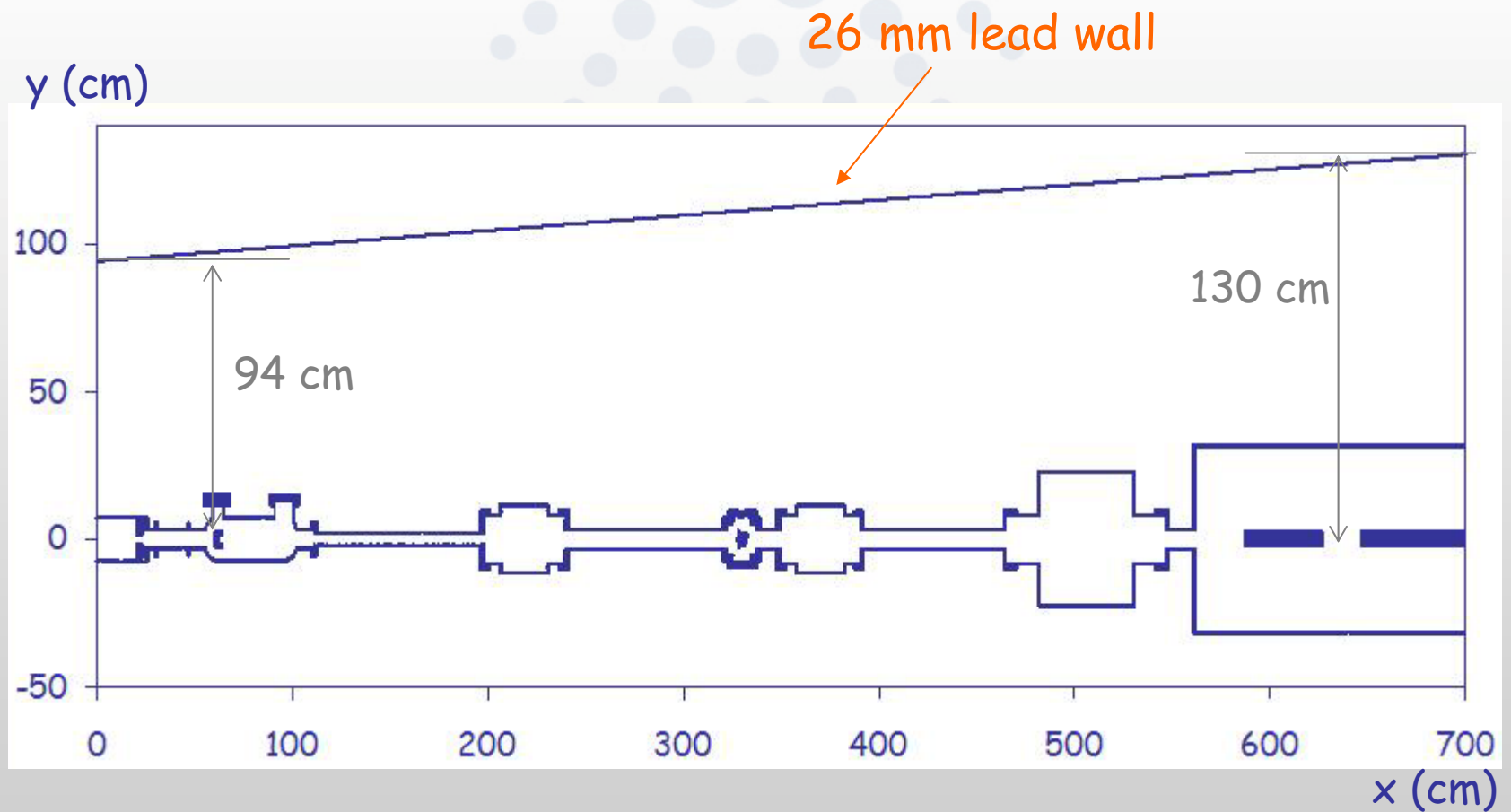

# ID12 - Circular polarisation beamline

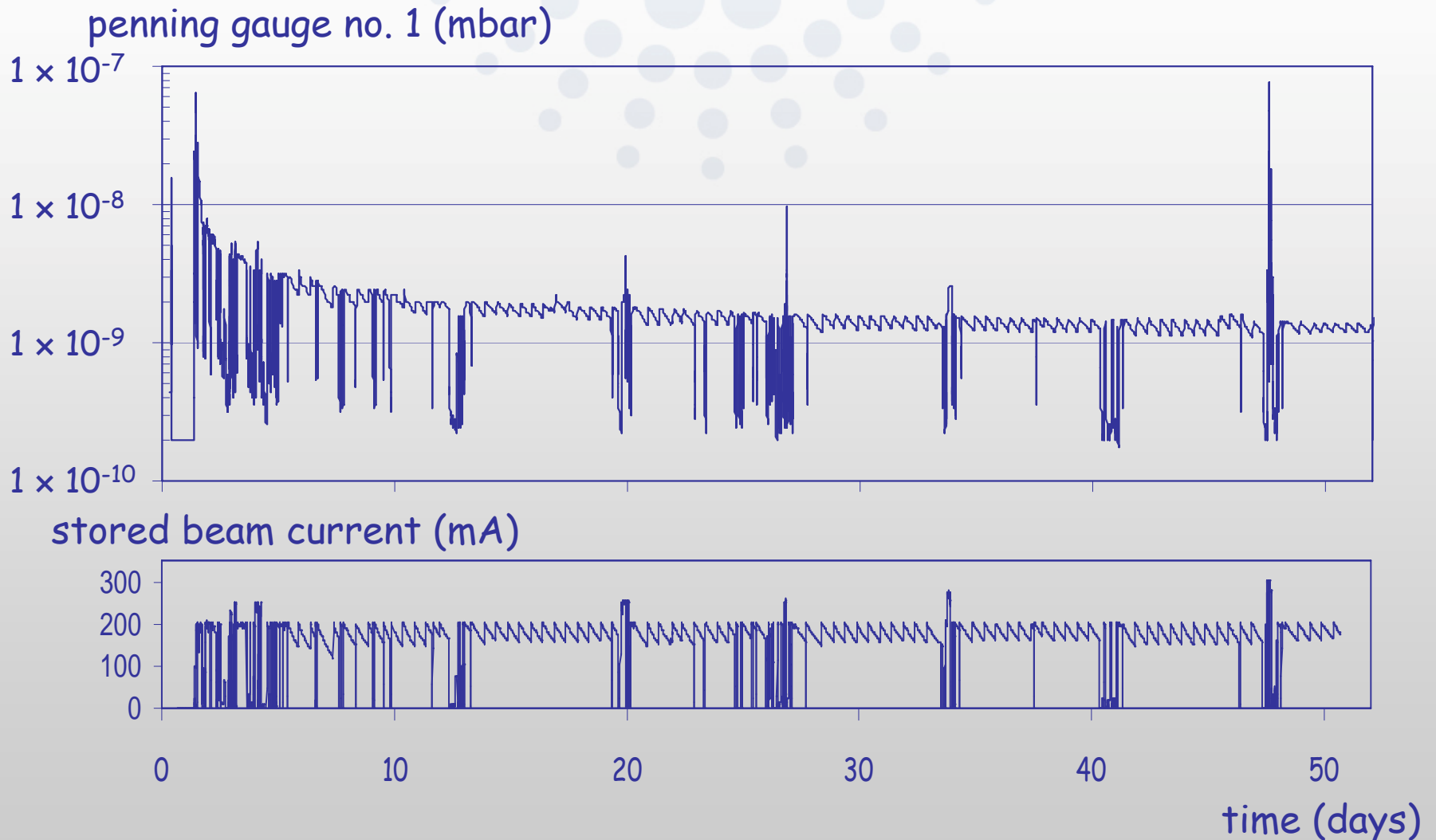

# ID12 - Circular polarisation beamline

$$\int I \times p_{\text{penning } 1} \cdot dt \text{ (mA} \times 10^{-9} \text{ mbar} \times \text{h)}$$

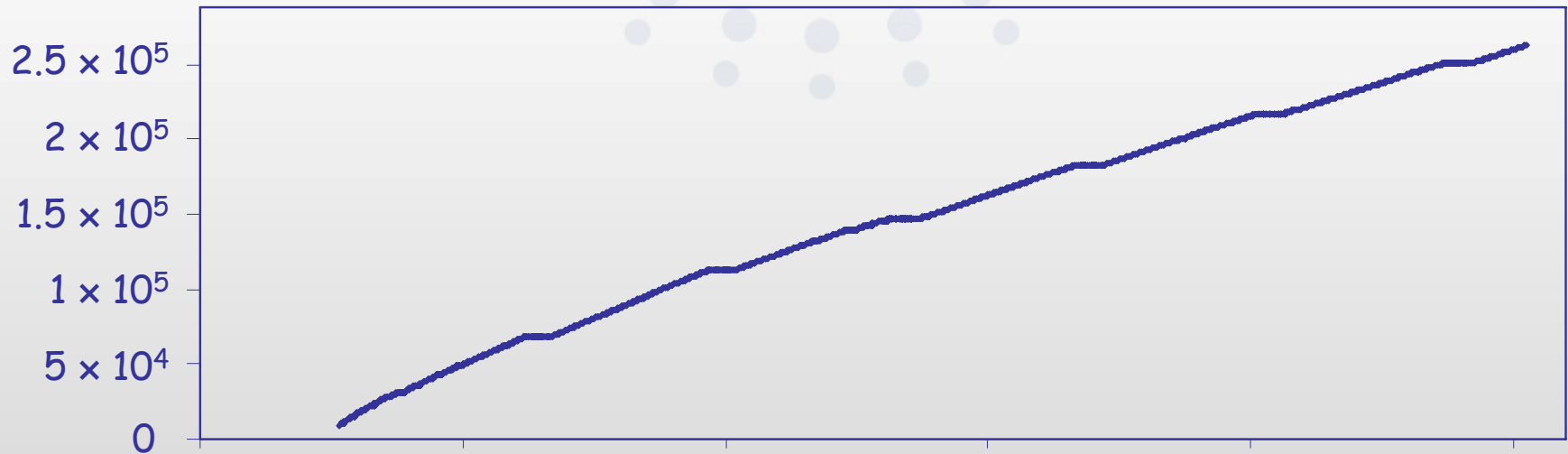

stored beam current during user operation (mA)

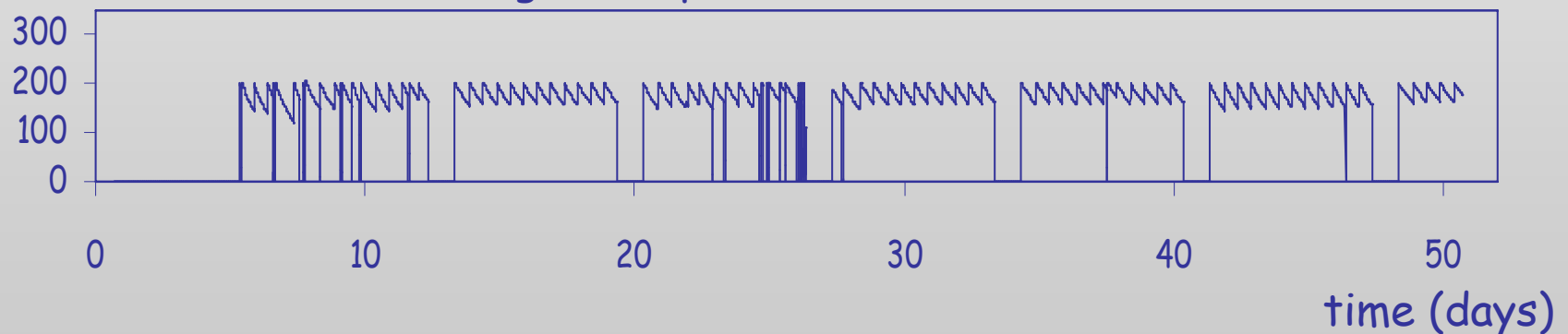

# ID12 - Circular polarisation beamline

$$\int I \times p_{\text{penning } 1} \cdot dt \text{ (mA} \times 10^{-9} \text{ mbar} \times \text{h)}$$

ambient dose equivalent ( $\mu\text{Sv}$ )

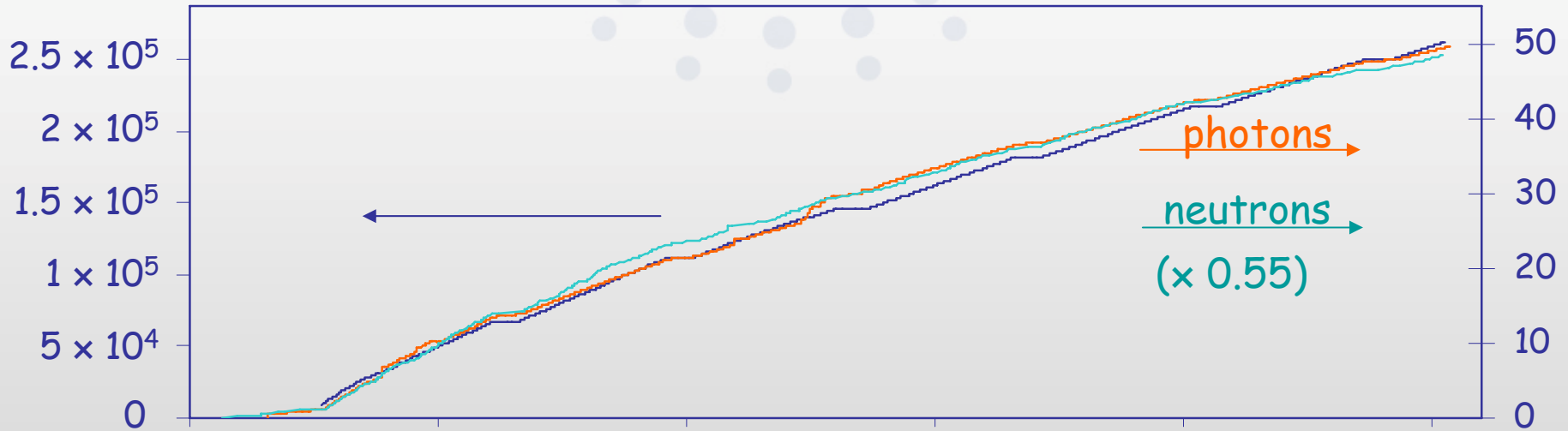
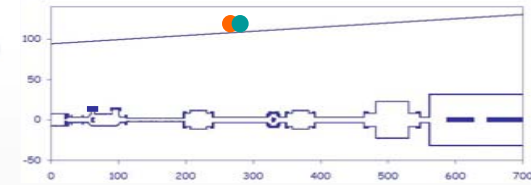

stored beam current during user operation (mA)

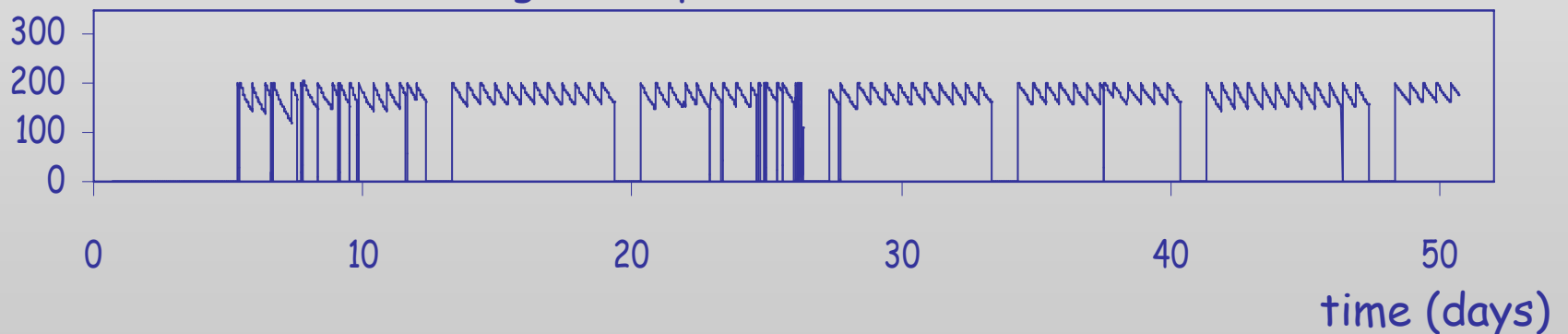

# ID12 - Circular polarisation beamline

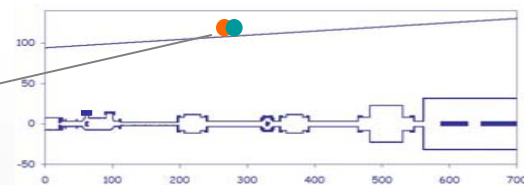

ambient dose equivalent rate ( $\mu\text{Sv/h}$ )

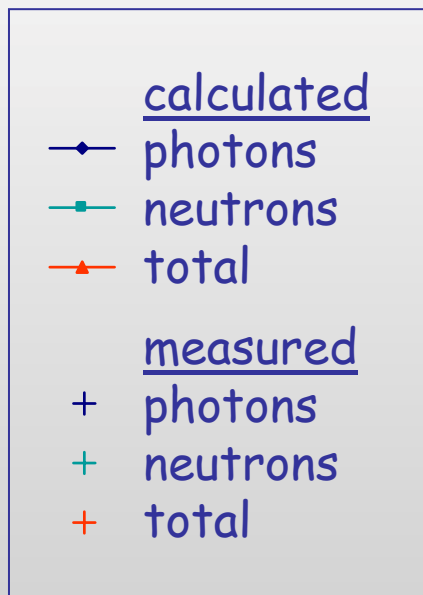
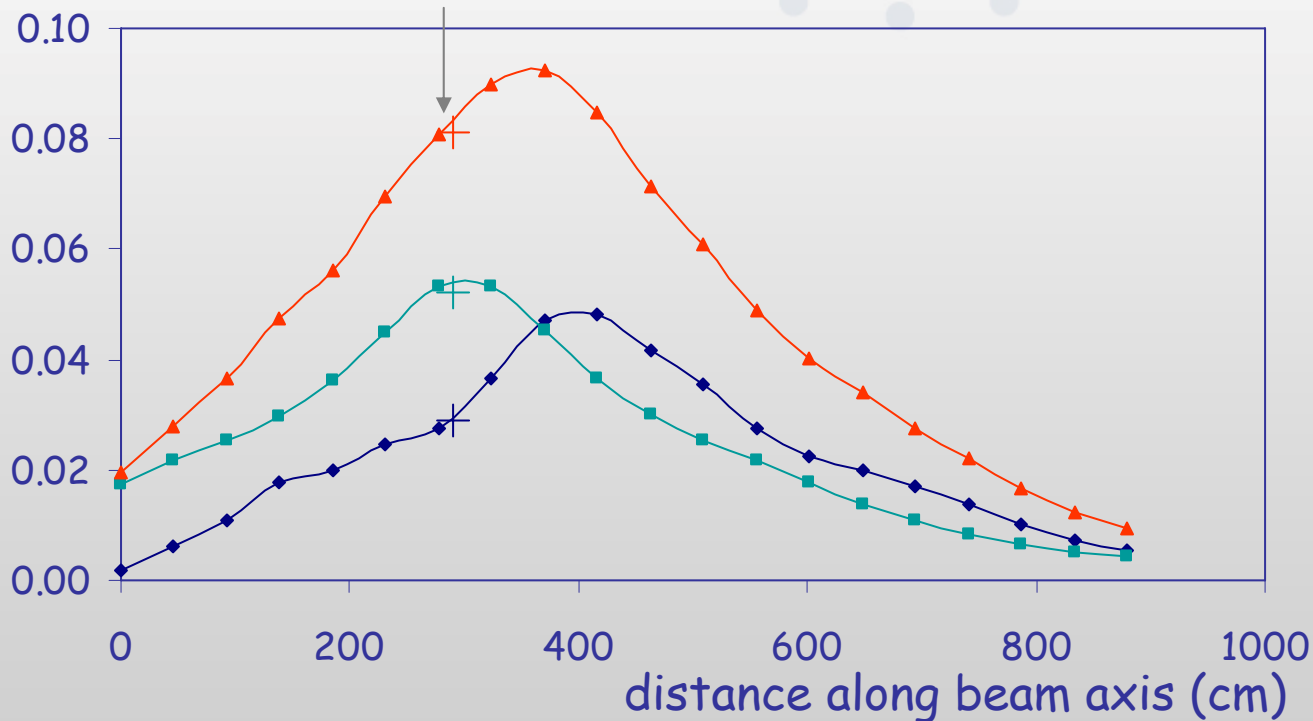

0.5  $\mu\text{Sv/h}$ :  
300 mA,  $3.8 \times 10^{-9}$  mbar

average pressure in straight section:  $1 \times 10^{-9}$  mbar  
stored beam current: 200 mA

# BM20 - SAXS-WAXS Dutch-Belgian CRG Beamline

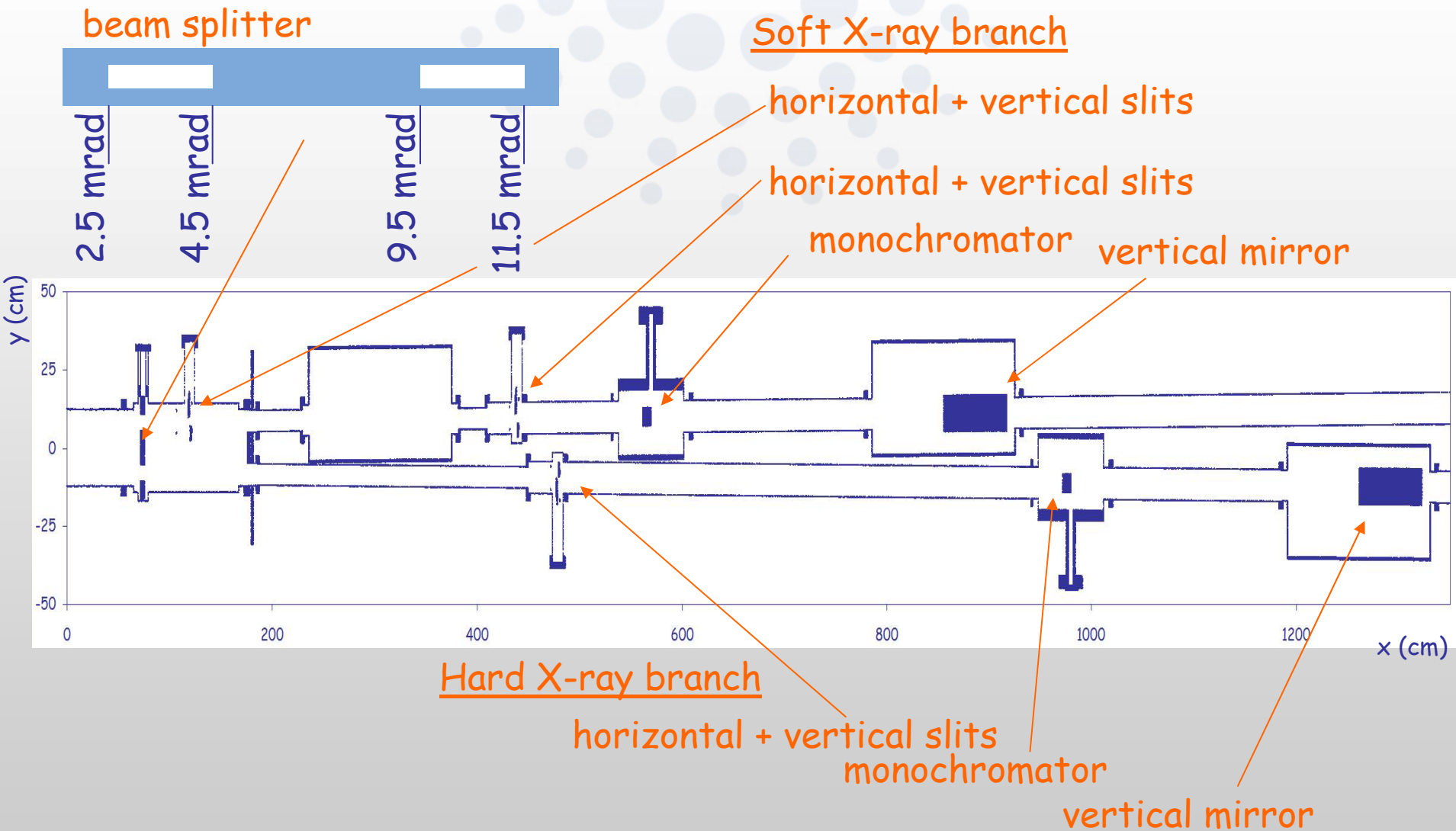

# BM20 - SAXS-WAXS Dutch-Belgian CRG Beamline

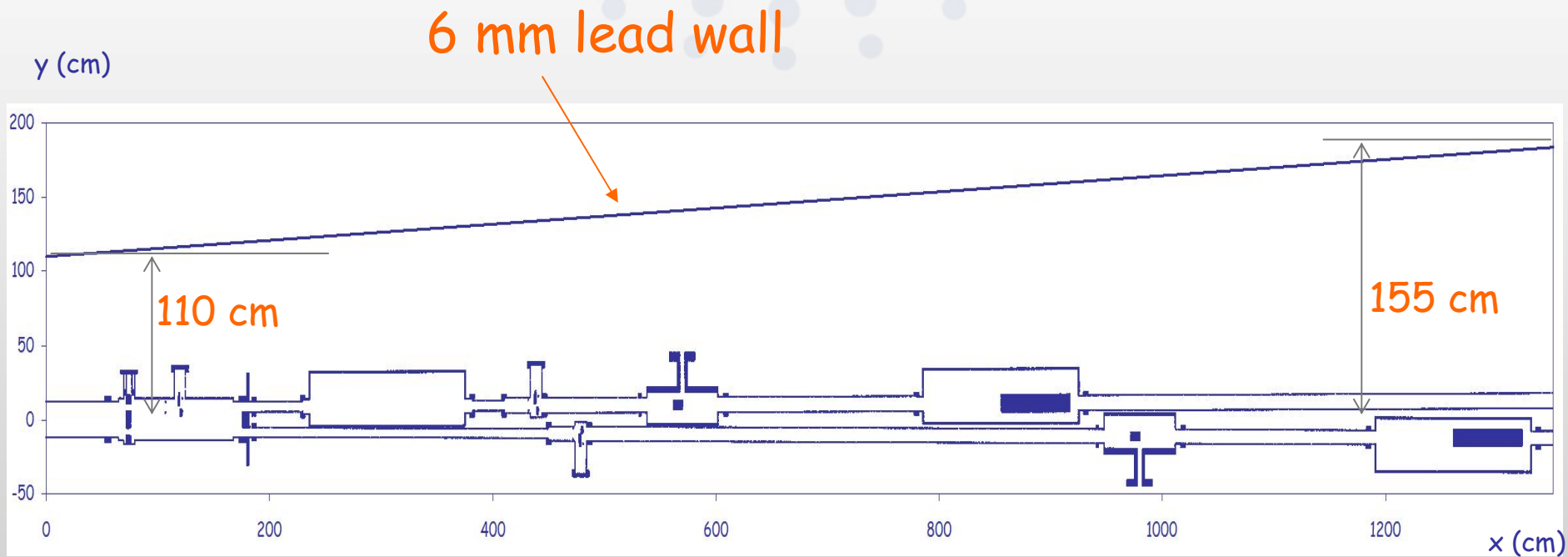

# BM20 - SAXS-WAXS Dutch-Belgian CRG Beamline

net photon ambient dose equivalent rate ( $\mu\text{Sv/h}$ )

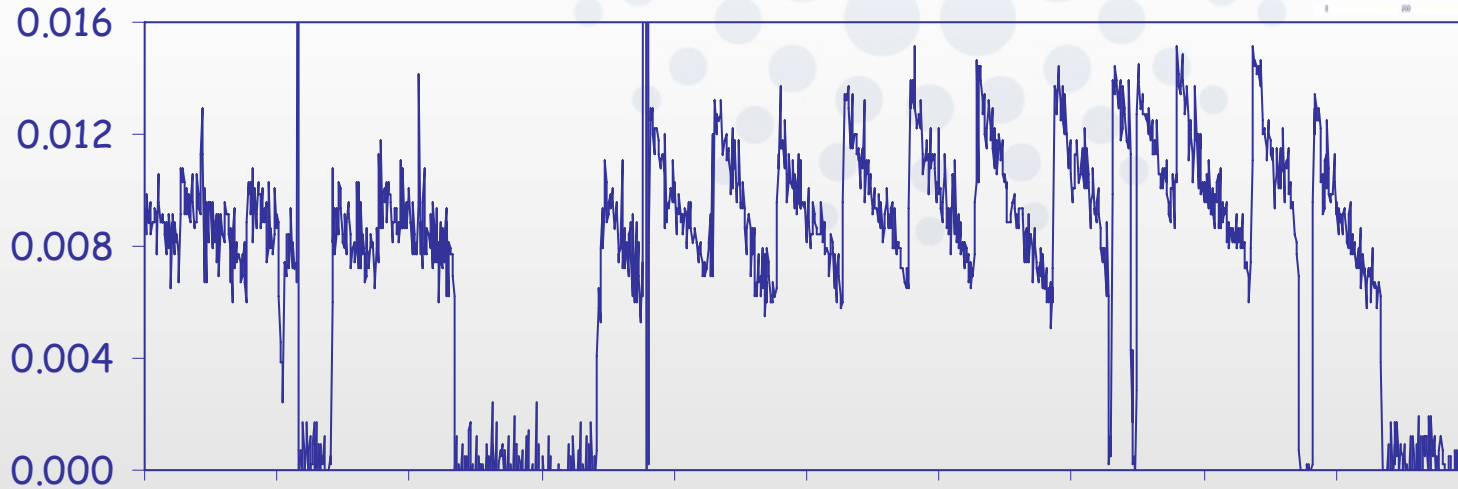
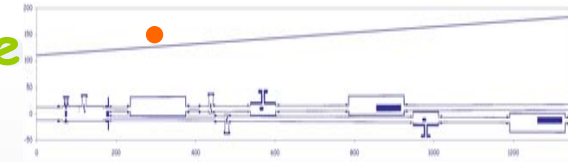

stored beam current (mA)

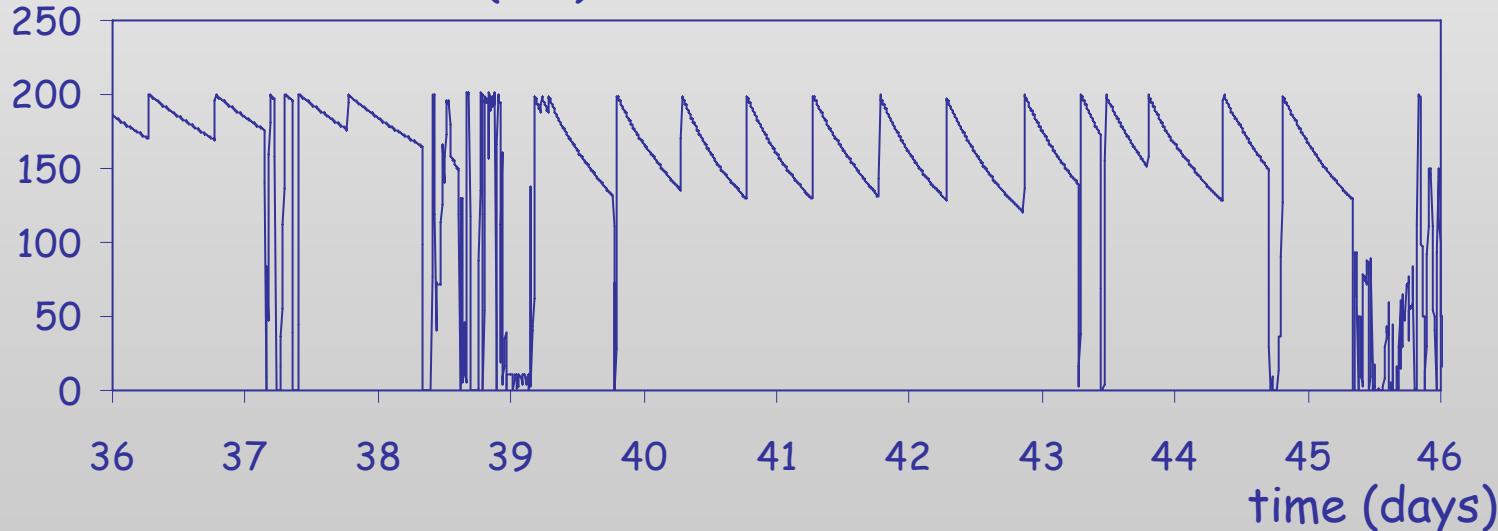

# BM20 - SAXS-WAXS Dutch-Belgian CRG Beamline

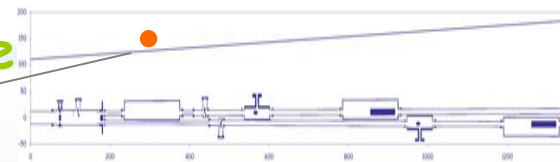

net photon ambient dose equivalent rate ( $\mu\text{Sv/h}$ )

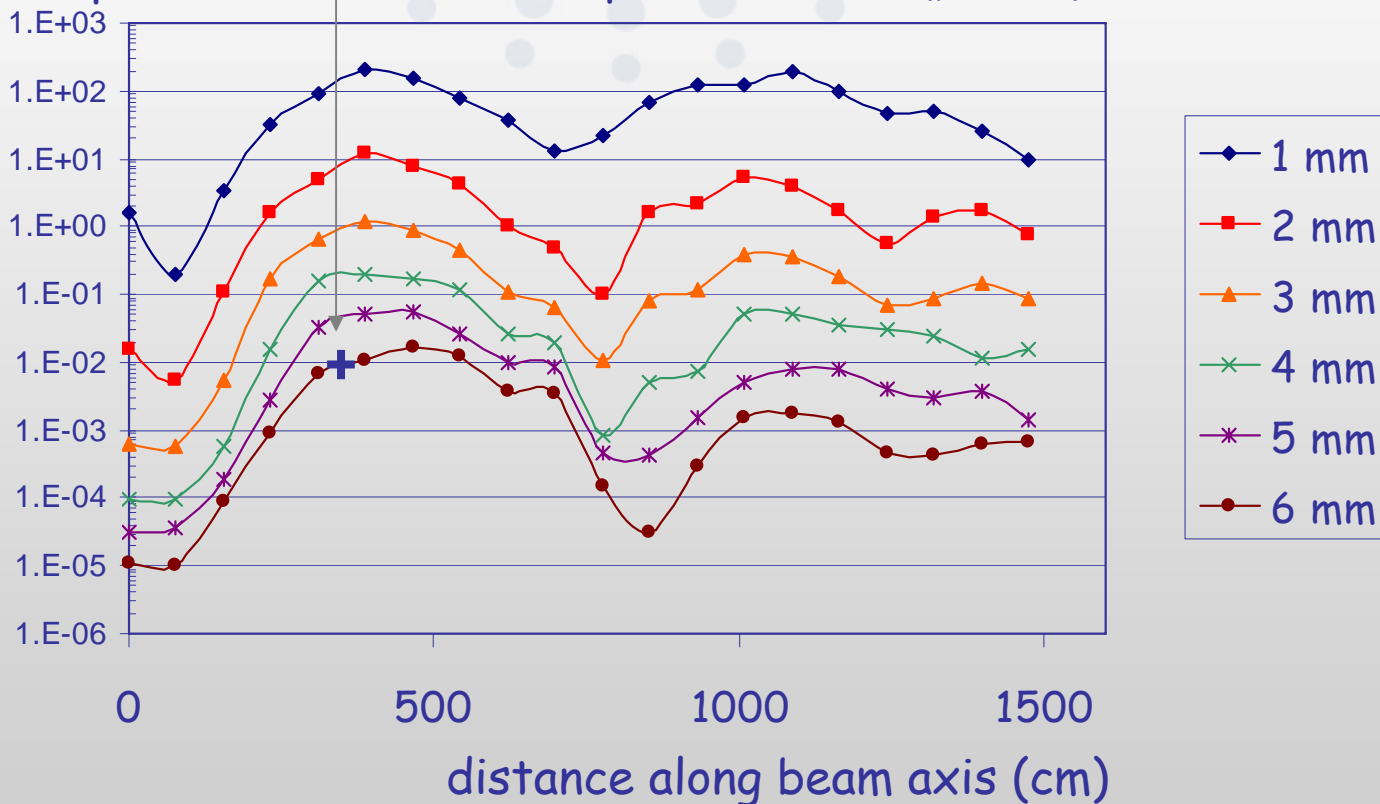

Results from shielding calculations using Monte Carlo code *Synchro* (P. Berkvens)

# Gas-bremsstrahlung source for bending magnet beamlines: example BM26

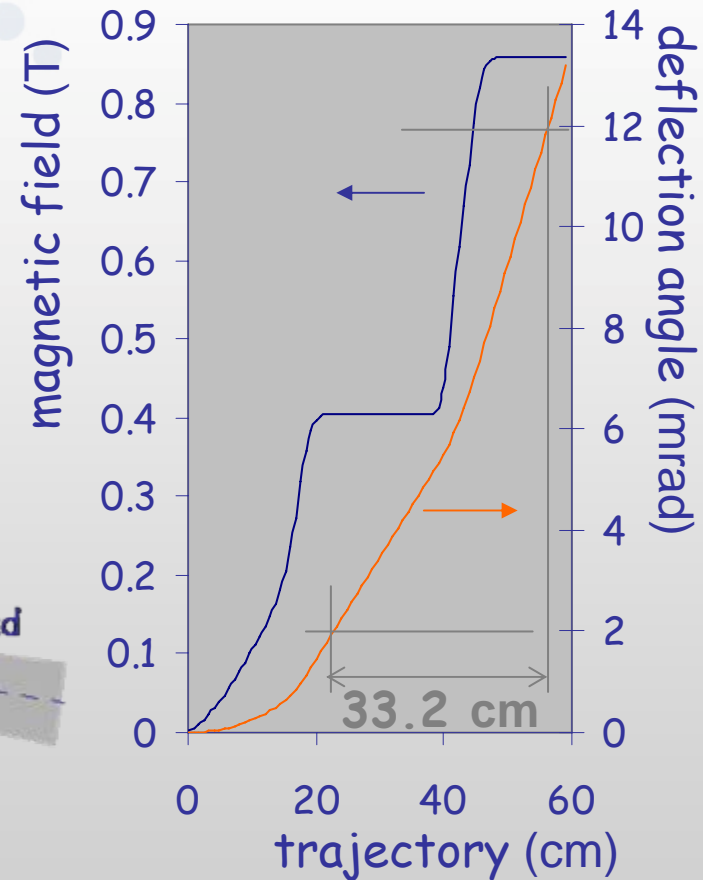
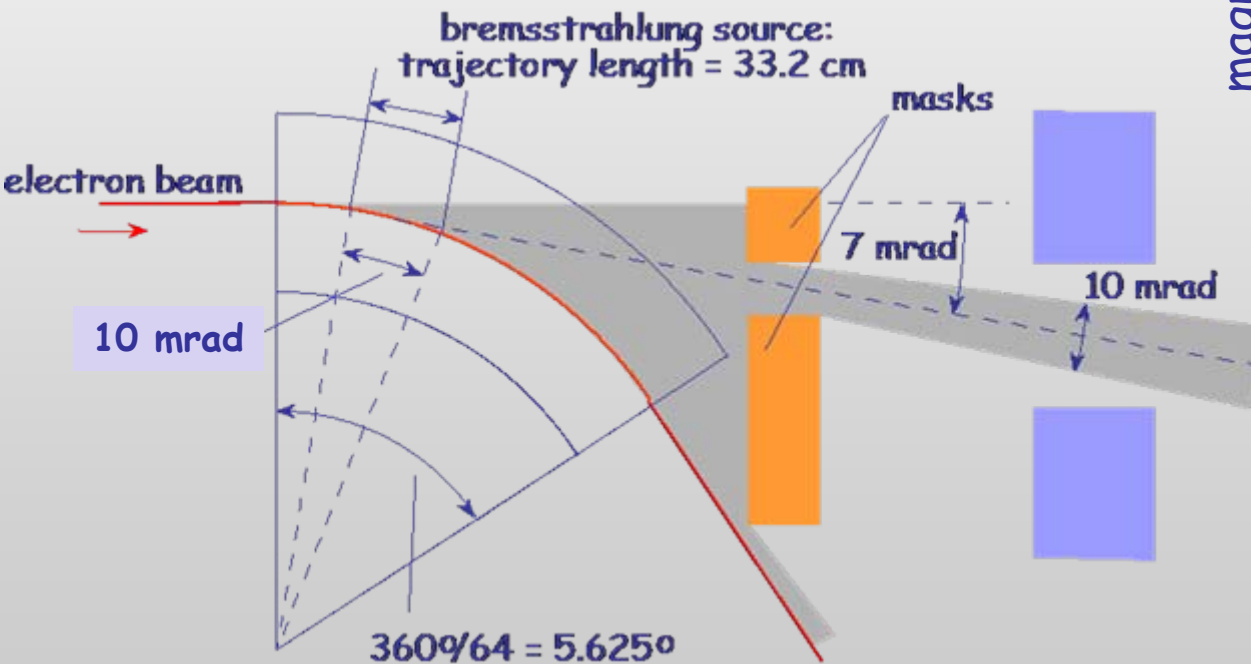

# Gas-bremsstrahlung source for bending magnet beamlines: example BM26

photon ambient dose equivalent rate ( $\mu\text{Sv/h}$ )

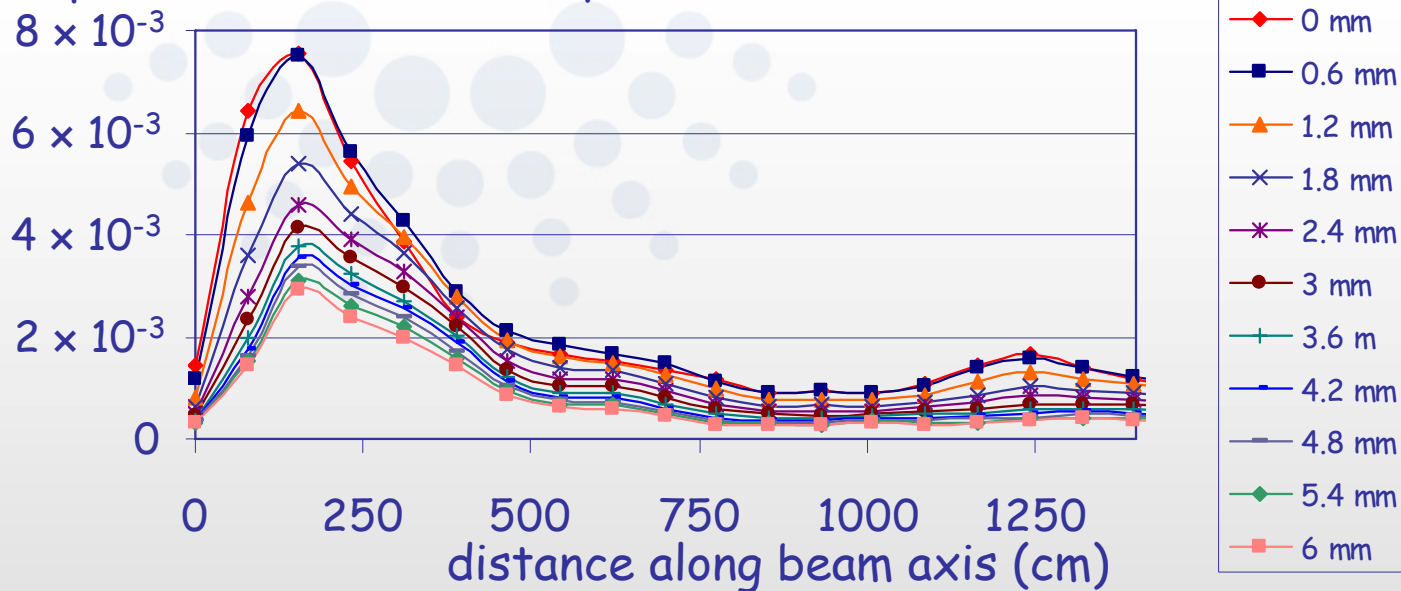

ambient dose equivalent rate ( $\mu\text{Sv/h}$ )

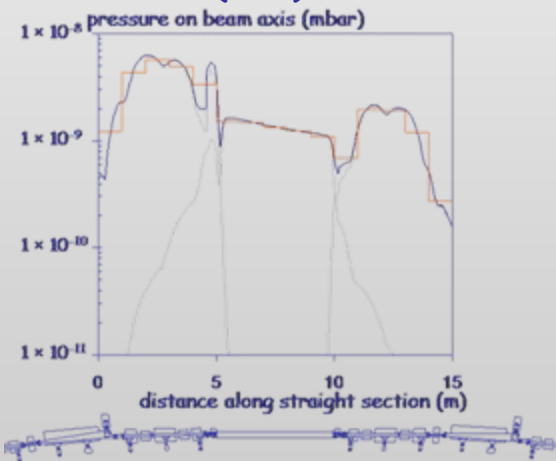
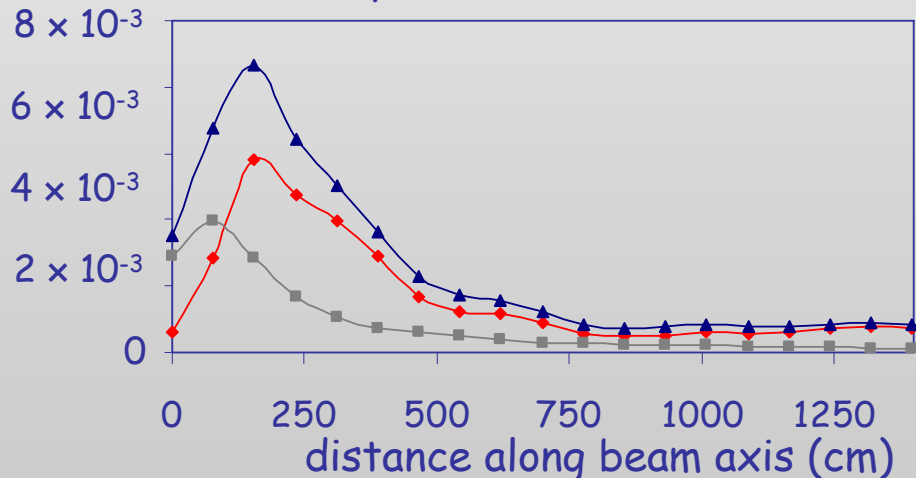

average pressure in dipole vessel:  $1 \times 10^{-9}$  mbar  
 stored beam current: 200 mA

## Conclusions

- ✚ The combination of the Monte Carlo codes *Molflow* and *BeamLines* gives a complete and accurate description of the shielding against gas-bremsstrahlung and photo-neutrons. This method has been validated using experimental results.
- ✚ The present ESRF radiation protection policy (respect of limits for non exposed workers, 2  $\mu\text{Sv}$  over 4 hours) will allow the operation of ID beamlines at 300 mA stored beam current up to average pressures in the straight section between 3 and  $7 \times 10^{-9}$  mbar.
- ✚ Downtime of ID beamlines due to excessive radiation levels outside the optics hutch should be minimal, thanks to the pre-conditioning of new ID vacuum vessels on the dedicated diagnostics/safety straight section.
- ✚ Neutrons contribute to a large extent to the radiation levels outside the optics hutches of ID beamlines.
- ✚ The present shielding of bending magnet beamlines will allow the operation of these beamlines at 300 mA.